



Heatshrink
North American
Product Guide

Moulded Shapes

HellermannTyton

INDEX

PRODUCTS	Styles	Determine which shapes suit your application and then refer to individual data sheets for appropriate sizes.	Pages 2-3
	Dimensions	Low Profile Shape Bulbous Shapes	Pages 10-18 Pages 19-58
MATERIALS	Selection Guide	A wide range of materials are available.	Pages 4
	Specification and Properties	For specific performance details refer to section pages.	Pages 6-7
ADHESIVES	Selection Guide	A wide range of adhesives are available.	Page 5
	Specification and Properties	For specific performance details refer to section pages.	Pages 8-9 and 60-61
MIL Spec/VG Spec Cross Reference		Parts of similar fit & function cross referenced from the MIL & VG Spec	Page 63-65
Tank Command Cross Reference		Parts of similar fit & function cross referenced from the Government ordnance spec.	Page 11
Moulded Part Bottle Shape Selection Guide to Suit MIL Spec Circular Connections		Shapes to suit Pat 602, MIL-C-26482 - I/II, Amphenol 62GB 162 GB PT, PTSE FK1, AB 05/06, All 38999/I/II/III/IV, MS 5015 AB, Litton CIR 6 & Amphenol 67 Series	Page 62
MIL Spec Cross Reference		Shapes to MS3109 & 3117	Page 63
Limited Fire Hazard Boot Backshell Assemblies			Page 64
VG Cross Reference			Page 65

SELECTION GUIDE

313C722 to 774 PAGE 12
CONVOLUTED BOOT, LOW
PROFILE, WITH ADAPTER LIP



313E445 to 457 PAGE 13
SHIM BOOT, LOW PROFILE,
NO ADAPTER LIP



313F322 to 396 PAGE 14
STAIHT BOOT, LOW PROFILE,
WITH ADAPTER LIP



333F232 PAGE 15
RIGHT ANGLE, BOOT 90°, LOW
PROFILE, WITH ADAPTER LIP

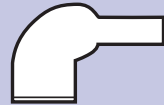

333F322 to 385 PAGE 15
RIGHT ANGLE, BOOT 90°, LOW
PROFILE, WITH ADAPTER LIP



414H622 to 625 PAGE 16
TRANSITION, T-90°, SIDE
BREAKOUT, LOW PROFILE



492H412 to 415 PAGE 17
TRANSITION, 1 to 2 CABLES, Y,
LOW PROFILE

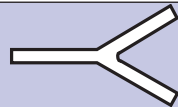

573H532 to 535 PAGE 18
TRANSITION, 1 to 3 CABLES,
LOW PROFILE

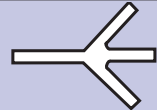

150 SERIES PAGE 20
BOTTLE SHAPES WITH RIB
VG STYLE



170 SERIES PAGE 28
BOTTLE SHAPES WITH RIB
VG STYLE

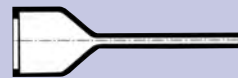

190 SERIES PAGE 29
BOTTLE SHAPE WITH EXTERNAL
RIBS VG STYLE



100 SERIES PAGE 21
BOTTLE SHAPES WITH RIB
MIL STYLE



100 SERIES PAGE 22
BOTTLE SHAPES WITHOUT
RIB



100 SERIES PAGE 23
BOTTLE SHAPES WITHOUT RIB
(THICK WALL)



120 SERIES PAGE 24
BOTTLE SHAPES WITHOUT
RIB



130 SERIES PAGE 25
LONG OUTLET SHAPES LOW
PROFILE WITH RIB



140 SERIES PAGE 26
LONG OUTLET SHAPES WITHOUT
RIB



160 SERIES PAGE 27
BOTTLE SHAPES WITHOUT
RIB



200 SERIES PAGE 30
2-WAY OUTLET SHAPES
LOW PROFILE

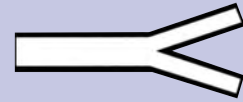

200 SERIES PAGE 31
2-WAY OUTLET SHAPES
VG STYLE



200 SERIES PAGE 32
2-WAY OUTLET SHAPES
IN LINE



300 SERIES PAGE 33
3-WAY OUTLET SHAPES
VG STYLE

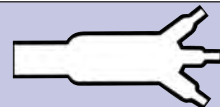

300 SERIES PAGE 34
3-WAY OUTLET SHAPES
IN LINE



400 SERIES PAGE 35
4-WAY OUTLET SHAPES
VG STYLE

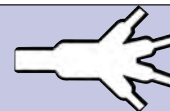





















400 SERIES PAGE 36
4-WAY OUTLET SHAPES
IN LINE



500 SERIES PAGE 37
5-WAY OUTLET SHAPES
IN LINE

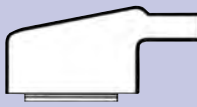

SELECTION GUIDE

<p>600 SERIES PAGE 38 6-WAY OUTLET SHAPE IN LINE</p>		<p>1300 SERIES PAGE 49 45° ANGLE T SHAPES VG STYLE</p>	
<p>1100 SERIES PAGE 39 RIGHT ANGLE SHAPES WITH RIB-VG STYLE</p>		<p>1310 SERIES PAGE 50 30° ANGLE DOUBLE T SHAPE</p>	
<p>1100 SERIES PAGE 40 RIGHT ANGLE SHAPES THICK WALL WITHOUT RIB-VG STYLE</p>		<p>1400 SERIES PAGE 51 90° ANGLE ELBOW SHAPES</p>	
<p>1100 SERIES PAGE 41 RIGHT ANGLE SHAPES WITH RIB MIL STYLE</p>		<p>1500 SERIES PAGE 52 CONNECTOR COVER FOR MIN -D SERIES WITH TOP ENTRY</p>	
<p>1100 SERIES PAGE 42 RIGHT ANGLE SHAPES WITHOUT RIB</p>		<p>1600 SERIES PAGE 53 END CAPS</p>	
<p>1100 SERIES PAGE 43 RIGHT ANGLE LOW PROFILE SHAPES WITH RIB-VG/MIL STYLE</p>		<p>1750 SERIES PAGE 54 GSR-GRADUATED STRAIN RELIEF SHAPES</p>	
<p>1100 SERIES PAGE 44 RIGHT ANGLE SHAPE LOW PROFILE HIGH RATIO WITH RIB VG STYLE</p>		<p>1760, 1790 PAGE 57 1820 SERIES LOCATING BUSHES</p>	
<p>1200 SERIES PAGE 45 T SHAPES VG STYLE</p>		<p>1800 SERIES PAGE 55 45° ANGLE SHAPES WITH RIB 30°, 45°, 60°</p>	
<p>1200 SERIES PAGE 46 OFF SET T SHAPES</p>		<p>2000 SERIES PAGE 56 RIGHT ANGLE CROSS SHAPE</p>	
<p>1200 SERIES PAGE 47 OFF SET T SHAPES VG STYLE</p>		<p>2100 SERIES PAGE 58 CONNECTOR COVER FOR MIN -D SERIES WITH SIDE ENTRY</p>	
<p>1300 SERIES PAGE 48 45° ANGLE T SHAPES VG STYLE</p>		<p>* OTHER PROFILES AVAILABLE ON REQUEST</p>	

NOTE

IN LINE WITH CUSTOMER DEMAND AND IN ORDER TO IMPROVE SERVICE, HELLERMANN TYTON HAS NOW ESTABLISHED A RANGE OF STANDARD PRODUCTS. THESE PRODUCTS AND MATERIALS ARE SHOWN ON THE RELEVANT PRODUCT PAGES AND ARE INDICATED *.

PLEASE CONTACT YOUR LOCAL SALES PERSON FOR AVAILABILITY.

SELECTION GUIDE FOR MOULDED SHAPES

HellermannTyton heatshrink moulded shapes are available in a variety of materials with a range of options. Using this guide you can select the optimum product to suit your application.

1. MATERIAL

Parts can be supplied in a wide variety of materials. The product data sheets reflect material availability for each specific part. Listed below is a summary of the material specifications.

To assist in your final selection, please refer to the full material specifications on pages 6-7.

HELLERMANN TYTON MOULDED SHAPES: MATERIALS SELECTION GUIDE

Material Reference	Description	Flame Retarded	Continuous Operating Temperature °C	Minimum Shrink Temperature °C	Specifications	Characteristics	Typical Applications
B7	Semi-rigid flame-retarded polyolefin	Yes	-55 to +135	+135	MIL-I-81765/1 TYPE 1 (DEF 59-97) BSG198 Pt 5	Good physical & chemical resistance	Military & general high performance harnessing
G	Fluid resistant elastomer	Yes	-75 to +150	+135	VG95343Pt6 (DEF 59-97) BSG198 Pt 5	Excellent resistance to fuels	Military & general high performance harnessing
J	Flexible Modified Polyolefin	Yes	-55 to +135	+135	MIL-I-81765/1 TYPE 2 (DEF 59-97) BSG198 Pt 5	Flexible	Military & general high performance harnessing
H	Flexible limited fire hazard material	Yes	-55 to +105	+135	NAVSEA5617649 (DEF 59-97) BSG198 Pt 5	Low smoke, halogen free	Ships, submarines & railways
B8	Semi-rigid polyolefin	Yes	-55 to +100	+135	ESI-0911	Good physical & reasonable multi outlet	Power/Utility breakout boots
L	Flexible modified Fluorocarbon	Yes	-55 to +200	+175	Conforms to MIL-I-81765/4 (DEF 59-97) BSG198 Pt 5	Excellent physical & chemical resistance	Fuel tanks and jet engines
9	Flexible Modified Elastomer	Yes	-55 to +120	+135	SCX15112	Good physical & chemical resistance	Military & general high performance harnessing
8	Flexible cross-linked modified fluoroelastomer blend	Yes	-55 to +150	+135	SCX15111	Excellent physical & chemical resistance	Military high performance harnessing
6	Flexible Modified Polyolefin	Yes	-55 to +120	+135	SCX15112	Flexible, good physical & chemical resistance	General harnessing applications

N.B. The standard color is black but for other specialised requirements, such as red for armaments systems or blue for commercial applications, please consult your local sales person.

SELECTION GUIDE FOR MOULDED SHAPES

2. ADHESIVES

Moulded shapes can be ordered with the option of an adhesive lining. The options are:

- WM250 – Hot melt adhesive. Operating temperature range -50°C to +80°C
- W1 – WM250 adhesive applied to NAVSEA specification requirements
- W8 – High temperature hot melt adhesive. Operating temperature range -55°C to +120°C
- W24 – One part epoxy. Operating temperature range -75°C to +200°C
- W2- Spiral lined Hot melt adhesive. operating temperature range -50°C to+80°C

For further details on specifications and properties including epoxy adhesives, see page 8-9.

3. SPECIAL MODIFICATIONS

Fillerports and drainholes are also available where it is desired to inject sealant.

P= Filler ports for potting - 0.12 inch \varnothing vent and 0.18 inch \varnothing filler.

D= Drain holes 4 off - 0.12 inch \varnothing at H end equally spaced 90° apart.

4. PRODUCT STYLE AND SIZE

Good working practice dictates that the shape should be selected so that when it is shrunk onto the component it is 20% larger than the fully recovered dimensions stated in the catalogue.

If you have any application not covered by our standard range, please refer to your local sales person.

6. ORDERING PROCEDURE

When ordering heatshrink shapes, it is necessary to give a complete part number to enable efficient processing of your order. Part numbers can be made up of the following typical components:-

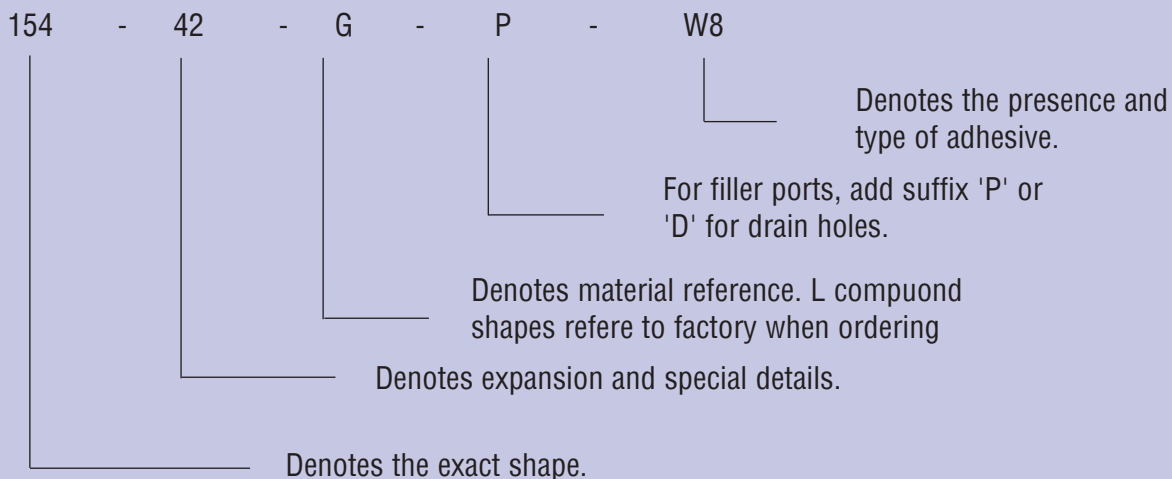

MATERIAL TESTS AND TYPICAL PROPERTIES

MATERIAL REFERENCE	B7	G	J	H
DESCRIPTION	Semi-rigid flame retarded polyolefin	Fluid resistant elastomer	Flexible modified polyolefin	Flexible limited fire hazard material
MINIMUM SHRINK TEMP °C	+135	+135	+135	+135
TEMPERATURE RANGE °C	-55 to +135	-75 to +150	-55 to +135	-55 to +105
STANDARD COLOUR	Black	Black	Black	Black
UK DEF STAN 59-97 REF	DA	DE	DB	DF
RELEVANT SPECIFICATIONS	Qualified to MIL-I-81765/1 Type 1 Semi-rigid Qualified to BSG198 Pt5 Issue 3 Type DA NAVSEA IA62	Qualified to VG95343 Part 6 Qualified to BSG198 Pt5 Issue 3 Type DE	Qualified to MIL-I-81765/1 Type II Flexible Qualified to BSG198 Pt5 Issue 3 Type DB	Qualified to VG95 343 Pt29 Issue 3 Type DF Conforms to NAVSEA 5617649

TYPICAL PROPERTIES

TENSILE STRENGTH	1885 psi	2175 psi	2030 psi	1450 psi
ELONGATION	500%	580%	610%	450%
HEAT AGEING ELONGATION	168 hours at +175°C 350%	168 hours at +160°C 500%	168 hours at +175°C 460%	168 hours at +150°C 430%
HEAT SHOCK	4 hours at +225°C No dripping, flowing or cracking	4 hours at +215°C Tensile Strength: 2320 PSI; Elongation: 550%	4 hours at +215°C No dripping, flowing or cracking	4 hours at +215°C No dripping, flowing or cracking
LOW TEMPERATURE FLEXIBILITY	Test temperature: -55°C No cracking	Test temperature: -75°C No cracking	Test temperature: -55°C No cracking	Test temperature: -55°C No cracking
FLAMMABILITY	Self extinguishes within 0.60 inch	Self extinguishes within 0.60 inch	Self extinguishes within 0.60 inch	Self extinguishes within 0.60 inch
DIELECTRIC STRENGTH	560V/mil	560V/mil	480V/mil	480V/mil
WATER ABSORPTION	0.1%	0.1%	0.13%	0.2%

SOLVENT RESISTANCE

SALINE	Excellent	Excellent	Excellent	Excellent
HYDRAULIC FLUID	Very Good	Very Good	Good	Good
LUBRICATING OIL	Very Good	Very Good	Good	Good
AVIATION FUEL	Good	Very Good	Fair	Fair
AUTOMOTIVE FUEL	Good	Very Good	Fair	Fair
DIESEL FUEL	Good	Very Good	Fair	Fair
DE-ICING FLUID	Excellent	Excellent	Very Good	Very Good

TEST METHODS: Tensile strength: IEC 540
Elongation: IEC 540
Heat Ageing: IEC 540
Heat Shock: ASTM D2671

Low Temperature Flexibility: ASTM D2671 Method C
Flammability: ASTM D635
Dielectric Strength: ASTM D2671
Water Absorption: ASTM D570

B8	L	-9	-8	-6
Semi-rigid polyolefin	Flexible modified fluorocarbon	Modified Elastomer	Flexible cross-linked modified fluoroelastomer blend	Flexible modified polyolefin
+135	+175	+135	+135	+135
-55 to +100	-55 to +200	-55 to +120°C	-55 to +150	-55 to +120°C
Black	Black	Black	Black	Black
-	DD	N/A	-	N/A
ESI 09-11 for UK Electricity Boards	Conforms to BSG 198 Pt5 Issue 3 Type DD Conforms to MIL-1-81765/4	Qualified to SCX 15112	Qualified to SCX15111	Conforms to MIL-1-81765/1 Type 1+2

2175 psi	1700psi	1700 psi	3000 psi	1700 psi
500%	300%	500%	450%	500%
168 hours at +175° 520%	168 hours at +250°C 250%	168 hours at +100°C 300%	168 hours at +150° 350%	168 hours at +100°C 300%
4 hours at +225°C No dripping, flowing or cracking	4 hours at +250°C No dripping, flowing or cracking	N/A	N/A	N/A
Test temperature: -55°C No cracking	Test temperature: -55°C No cracking	Test temperature: -60°C No cracking	Test temperature: -60°C No cracking	Test temperature: -60°C No cracking
Self extinguishes within 1 inch	Non-burning (Self extinguishes within 0.60 inch)	Self extinguishes within 0.60 inch	Self extinguishes within 0.60 inch	Self extinguishes within 0.60 inch
440V/mil	200V/mil	600V/mil	650V/mil	600V/mil
0.3%	0.5% (24hrs at 23°C)	0.15%	0.15%	0.15%

Excellent	Very Good	Excellent	Excellent	Excellent
Good	Excellent	Good	Very Good	Good
Very Good	Excellent	Good	Very Good	Good
Fair	Excellent	Fair	Very Good	Fair
Fair	Excellent	Fair	Very Good	Fair
Fair	Excellent	Fair	Very Good	Fair
Very Good	Excellent	Very Good	Excellent	Very Good

ADDITIONAL PROPERTIES OF LIMITED FIRE HAZARD MATERIAL (H)

Toxicity Index: 1.9
Smoke Index: 9.0
Temperature Index: 250
Oxygen Index: 31.4

Test method: NES 713
Test method: NES 711
Test method: NES 715
Test method: ISO 4589

TYPICAL PROPERTIES AND TESTS FOR ADHESIVES COATED TO ELECTRONIC PARTS

TYPE	WM250/W2-pre-applied	TSA-200 * Not pre-coated	-109
DESCRIPTION	WM250/W2 is a hot melt adhesive which has an operating range of -50°C to +80°C. Product is Halogen free	Thermoset adhesive operating temperature -55°C+125°C	Reactive hot melt adhesive which has an operating temperature range of -55°C to +125°C
RELEVANT SPECIFICATION	Conforms to BSG 198 Pt5	Conforms to BSG198 Pt5	Conforms to Def.Stan 59-97 issue 3 Type S
SOFTENING POINT	+95°C	N/A	N/A
CURE TIME	N/A	30 minutes at +150°C	30 minutes at 150°C or 2hrs at 80°C
PEEL STRENGTH	XLPE/Metal 33lbs/inch XLPE/XLPE 18lbs/inch	XLPE/Metal 35lbs/inch XLPE/XLPE 25lbs/inch	XLPE / METAL 37lb/inch XLPE / METAL 37lb/inch PVC / PVC 14lb/inch
DYNAMIC SHEAR Backshell / boot / cable Shell size 22	80lbs at +23°C	120lbs at +23°C	78lb at 23°C
LAP SHEAR Area - (1/2" x 1")	XLPE/Metal 44lbs at +23°C	XLPE/Metal 55lbs 4hrs/+215°C	XLPE / METAL 56lb XLPE / XLPE 60lb PVC / PVC 15lb
THERMAL SHOCK Peel Strength	N/A	XLPE/XLPE 22lbs/inch	N/A
SOLVENT RESISTANCE	Fair under splash conditions	Excellent	Excellent under splash conditions
APPLICATION	Good general purpose adhesive bonds to most materials	Excellent for fluid resistant applications	Reactive Hot melt adhesive that is primarily used with low profile shapes

W24 - Pre applied	W8 - Pre-applied / -450	V9500 * Not pre-coated
W24 is a factory coated high performance epoxy adhesive. Operating temperature of -75°C to +200°C	W8 is a modified polyamide hot melt adhesive which has an operating temperature of -55°C to +120°C. Product is Halogen free	V9500 is a two part black epoxy adhesive which has an operating temperature of -75°C to +150°C.
Conforms to BSG 198 Pt5 Type Qualified to VG95343 Part 18	Conforms BSG 198 Pt5	Conforms BSG 198 Pt5 Qualified to VG95343 T15A 0001
-	+105°C	-
50% of bond strength achieved when cool to enable movement of Harnesses. Ultimate strength reached in 7 days	N/A	Product cures to a tack free condition in 24 hours at +25°C. Heating the assembly for 2 hours at +85°C will produce accelerated curing
XLPE/Metal 22lbs/inch XLPE/XLPE 30lbs/inch	XLPE/XLPE 20lbs/inch	XLPE/XLPE 25lbs/inch
330lb at +23°C	77lbs at +23°C	120lbs at +23°C
Al/Al 1540lb at 23°C Al/Al 220lbs/inch	XLPE/Metal 40lbs at +23°C	Metal/Metal 1540lbs at +23°C
4 hours at 215°C XLPE/XLPE 22lbs/inch	N/A	4 hours / +215°C XLPE/XLPE 22lbs/inch
De-icing Fluid – Excellent Petrol – Excellent Lubricating Oil – Excellent Hydraulic Fluid – Excellent	Fair under splash conditions	De-icing Fluid - Excellent Gasoline - Excellent Lubricating Oil - Excellent Hydraulic Fluid - Excellent
Flexible epoxy adhesive. For fluid resistant and use in harsh environments and elevated temperatures. Excellent fluid resistance. performs well in harsh environments and at elevated temperatures	High temperature hot melt. Bonds well to polythene and metals. Compliments -H material	Excellent for fluid resistant applications



**Low Profile
Boots and Transitions**

INTRODUCTION TO LOW PROFILE SHAPES



HEAT-SHRINKABLE LOW PROFILE SHAPES U.S. MILITARY VEHICLE TACOM CROSS REFERENCE

Description	Government Ordnance No.	Part No.	Government Ordnance No.	Part No.
Straight Boot	12273147-120	313F322-9	12273147-130	313F322-8
	12273147-220	313F332-9	12273147-230	313F332-8
	12273147-320	313F343-9	12273147-330	313F343-8
	12273147-420	313F353-9	12273147-430	313F353-8
	12273147-520	313F364-9	12273147-530	313F364-8
	12273147-620	313F374-9	12273147-630	313F374-8
	12273147-720	313F385-9	12273147-730	313F385-8
Right Angle Boot	12273176-120	333F322-9	12273176-130	333F322-8
	12273176-220	333F332-9	12273176-230	333F332-8
	12273176-320	333F343-9	12273176-330	333F343-8
	12273176-420	333F353-9	12273176-430	333F353-8
	12273176-520	333F364-9	12273176-530	333F364-8
	12273176-620	333F374-9	12273176-630	333F374-8
	12273176-720	333F385-9	12273176-730	333F385-8
Convolute Boot	12273242-110	313C722-9	12273242-120	313C722-8
	12273242-210	313C732-9	12273242-220	313C732-8
	12273242-310	313C743-9	12273242-320	313C743-8
	12273242-410	313C753-9	12273242-420	313C753-8
	12273242-510	313C764-9	12273242-520	313C764-8
	1271867-610	313C774-9		
Transition "T"	12273162-110	412H622-9	12273162-120	412H622-8
	12273162-210	412H623-9	12273162-220	412H623-8
	12273162-310	412H624-9	12273162-320	412H624-8
	12273162-410	412H625-9	12273162-420	412H625-8
Transition "Y"	12273148-110	492H412-9	12273148-120	492H412-8
	12273148-210	492H413-9	12273148-220	492H413-8
	12273148-310	492H414-9-01	12273148-320	492H414-8-01
	12273148-410	492H415-9-01	12273148-420	492H415-8-01
Shim Boot	12273164-110	313E445-9	12273164-120	313E445-8
	12273164-210	313E455-9	12273164-220	313E455-8
	12273164-310	313E447-9	12273164-320	313E447-8
	12273164-410	313E457-9	12273164-420	313E457-8
Transition 3 to 1	12273163-110	573H532-9	12273163-120	573H532-8
	12273163-210	573H533-9	12273163-220	573H533-8
	12273163-310	573H534-9	12273163-320	573H534-8
	12273163-410	573H535-9	12273163-420	573H535-8

All crosses are accurate and true and based on revisions that were currently available, all references should be checked against latest revisions/drawings before ordering

313C722-774

CONVOLUTED BOOT,
LOW PROFILE
WITH ADAPTER LIP



This style is used with a circular grooved adapter to provide strain relief and, if adhesive is used, environmental sealing.

The convoluted design provides the flexibility to accommodate different cable outlet angles.

EXPANDED, AS SUPPLIED, PART



FULLY RECOVERED PART (AFTER HEATING)

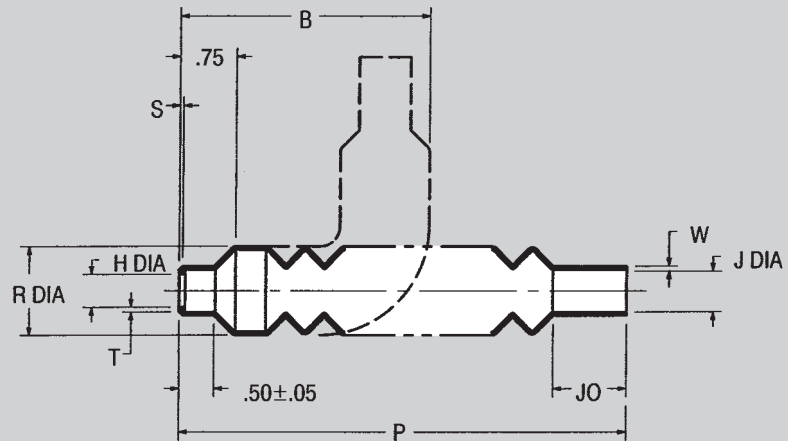

1. All dimensions are in inches – all angles in degrees.
2. Dimensions in table:
X = Expanded (minimum);
R = Recovered (maximum)
3. Colour: Black

Part Number	H DIA		J DIA		P ±10% R	R MAX R	JO ±10% R	W MIN R	B NOM R	T ±0.03 R	S ±.03 R
	MIN X	MAX R	MIN X	MAX R							
313C722	0.56	0.27	0.44	0.19	4.75	0.83	0.69	0.060	2.46	0.05	0.06
313C732	0.88	0.46	0.70	0.32	5.25	1.05	0.78	0.060	2.67	0.05	0.06
313C743	1.34	0.69	1.06	0.50	5.75	1.29	0.88	0.060	2.89	0.05	0.07
313C753	1.74	0.88	1.44	0.69	6.25	1.49	1.00	0.060	3.08	0.05	0.07
313C764	2.12	1.10	1.80	0.88	6.75	1.69	1.12	0.060	3.26	0.08	0.07
313C774	3.04	1.60	2.15	0.90	9.30	2.45	1.38	0.060	5.45	0.08	0.08

MATERIALS AVAILABLE

- 6 Flexible modified Polyolefin
- 8 Flexible cross-linked modified fluoroelastomer blend
- *-9 Flexible modified Elastomer

ADHESIVE OPTIONS

Adhesive (Part Numbers)	Factory Applied	Description
TSA-200	-200	Thermoset 125°C
TTS-250	-250	Thermoplastic 80°C
TTS-450	-450	Thermoplastic 120°C
W24	W24	1 Part Epoxy 200°C

313E445-457

SHIM BOOT,
LOW PROFILE,
NO ADAPTER LIP



EXPANDED, AS SUPPLIED, PART

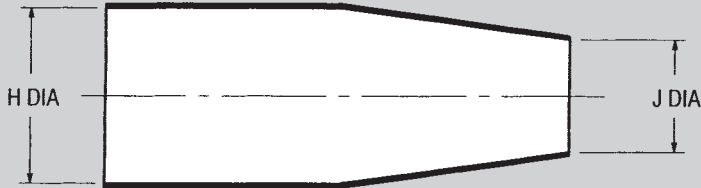

FULLY RECOVERED PART (AFTER HEATING)

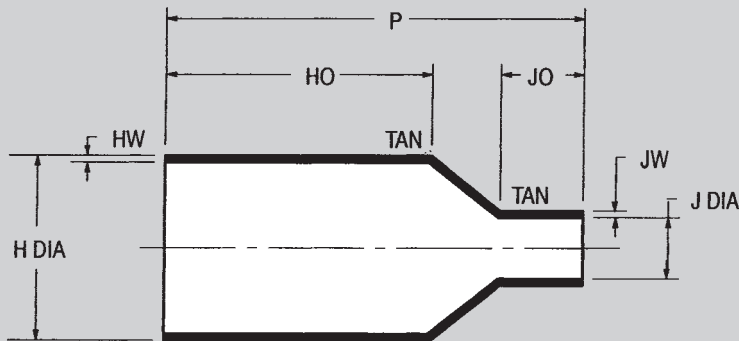

This part is normally used to build up, or shim a cable diameter to facilitate a better fit for components in a cable harness.

1. All dimensions are in inches – all angles in degrees.
2. Dimensions in table:
X = Expanded (minimum);
R = Recovered (maximum)
3. Colour: Black

Part Number	H DIA		J DIA		P ±10% R	HO ±10% R	HW ±25% R	JW ±25% R	JO ±10% R
	MIN X	MAX R	MIN X	MAX R					
313E445	0.50	.50+.08/-0.00	0.44	0.13	2.50	1.62	0.06	0.06	0.62
313E455	0.87	.87+.14/-0.00	0.44	0.13	2.10	1.10	0.09	0.06	0.62
313E447	0.82	.50+.08/-0.00	0.81	0.39	2.50	1.62	0.06	0.06	0.65
313E457	0.87	.87+.14/-0.00	0.81	0.39	2.10	1.10	0.09	0.06	0.55

MATERIALS AVAILABLE

- 6 Flexible modified Polyolefin
- 8 Flexible cross-linked modified fluoroelastomer blend
- *-9 Flexible modified Elastomer

ADHESIVE OPTIONS

Adhesive (Part Numbers)	Factory Applied	Description
TSA-200	-200	Thermoset 125°C
TTS-250	-250	Thermoplastic 80°C
TTS-450	-450	Thermoplastic 120°C
W24	W24	1 Part Epoxy 200°C

313F322-396

STRAIGHT BOOT,
LOW PROFILE
WITH ADAPTER LIP



This boot provides strain relief in applications with partially loaded connectors, resulting in small cable diameters requiring a high shrink ratio.

EXPANDED, AS SUPPLIED, PART



FULLY RECOVERED PART (AFTER HEATING)

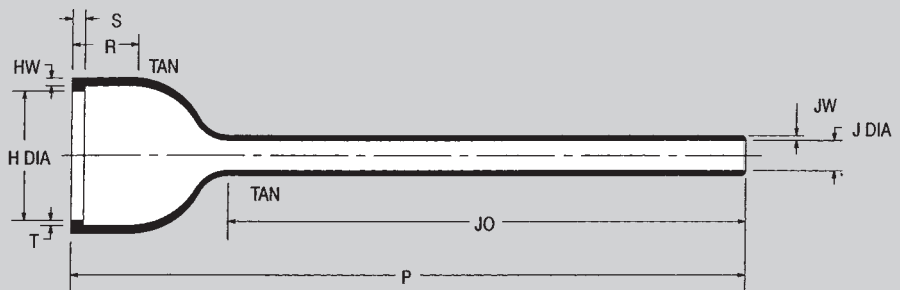

1. All dimensions are in inches – all angles in degrees.
2. Dimensions in table:
X = Expanded (minimum);
R = Recovered (maximum)
3. Colour: Black

Part Number	H DIA		J DIA		P ±10% R	R ±15% R	T ±0.03 R	JO ±10% R	HW +0.06 -0.03 R	JW ±0.03 R	S +0.06 -0.03 R
	MIN X	MAX R	MIN X	MAX R							
313F322	0.94	0.39	0.68	0.26	4.17	0.46	0.05	3.40	0.06	0.06	0.06
313F332	1.07	0.52	0.82	0.30	4.77	0.48	0.05	3.88	0.06	0.06	0.06
313F343	1.22	0.73	0.96	0.35	5.46	0.48	0.05	4.44	0.07	0.06	0.07
313F353	1.40	0.87	1.13	0.40	6.28	0.48	0.05	5.15	0.07	0.06	0.07
313F364	1.53	1.11	1.24	0.43	7.00	0.55	0.07	5.60	0.07	0.06	0.07
313F374	1.78	1.27	1.51	0.50	8.00	0.60	0.07	6.42	0.07	0.06	0.07
313F385	2.03	1.79	1.79	0.59	8.00	0.60	0.07	6.21	0.07	0.07	0.07
313F396	2.47	1.79	2.10	0.66	9.00	0.63	0.07	6.03	0.07	0.07	0.07

MATERIALS AVAILABLE

- 6 Flexible modified Polyolefin
- 8 Flexible cross-linked modified fluoroelastomer blend
- *-9 Flexible modified Elastomer

ADHESIVE OPTIONS

Adhesive (Part Numbers)	Factory Applied	Description
TSA-200	-200	Thermoset 125°C
TTS-250	-250	Thermoplastic 80°C
TTS-450	-450	Thermoplastic 120°C
W24	W24	1 Part Epoxy 200°C

333F322-385

RIGHT ANGLE, BOOT
90°, LOW PROFILE
WITH ADAPTER LIP



This boot provides connector cable strain relief in applications with partially loaded connectors resulting in small cable diameters requiring a high shrink ratio.

1. All dimensions are in inches – all angles in degrees.
2. Dimensions in table:
X = Expanded (minimum);
R = Recovered (maximum)
3. Colour: Black

EXPANDED, AS SUPPLIED, PART

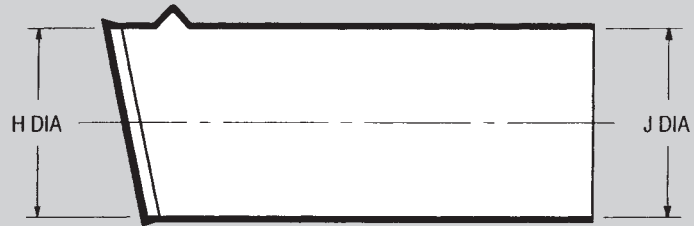

FULLY RECOVERED PART (AFTER HEATING)

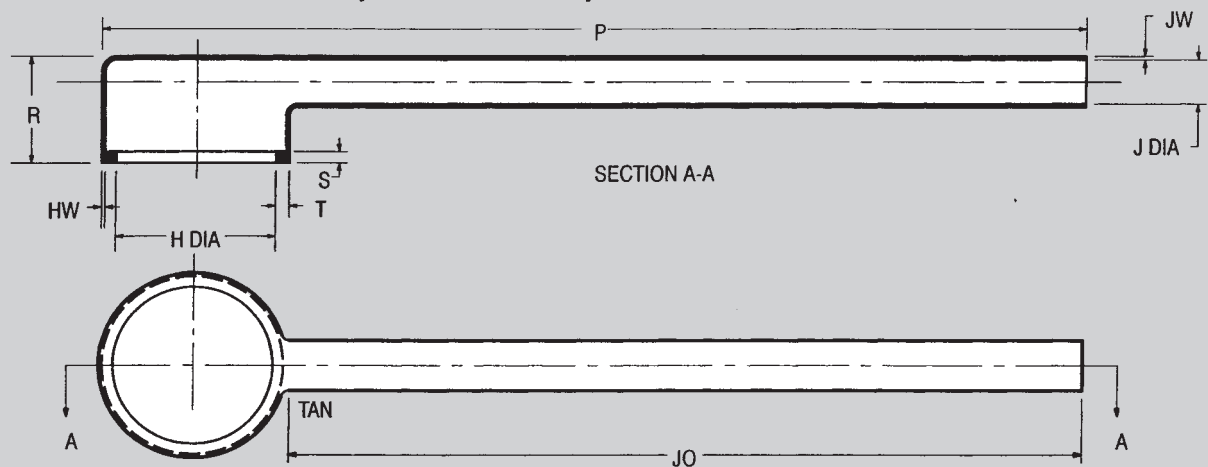

Part Number	H DIA		J DIA		P ±10% R	R ±15% R	T ±0.03 R	JO ±10% R	HW +0.06 -0.03 R	JW ±0.03 R	S +0.06 -0.03 R
	MIN X	MAX R	MIN X	MAX R							
333F322	0.94	0.39	0.68	0.26	4.14	0.73	0.05	3.45	0.06	0.06	0.06
333F332	1.07	0.52	0.82	0.29	4.56	0.78	0.05	3.90	0.06	0.06	0.06
333F343	1.22	0.73	0.96	0.33	5.76	0.82	0.05	4.50	0.07	0.06	0.07
333F353	1.40	0.85	1.13	0.40	6.78	0.86	0.05	5.22	0.07	0.06	0.07
333F364	1.53	1.10	1.24	0.43	7.29	0.95	0.07	5.66	0.07	0.06	0.07
333F374	1.78	1.34	1.51	0.48	8.41	1.08	0.07	6.66	0.07	0.06	0.07
333F385	2.03	1.62	1.75	0.56	8.84	1.16	0.07	6.82	0.07	0.07	0.07

MATERIALS AVAILABLE

- 6 Flexible modified Polyolefin
- 8 Flexible cross-linked modified fluoroelastomer blend
- *-9 Flexible modified Elastomer

ADHESIVE OPTIONS

Adhesive (Part Numbers)	Factory Applied	Description
TSA-200	-200	Thermoset 125°C
TTS-250	-250	Thermoplastic 80°C
TTS-450	-450	Thermoplastic 120°C
W24	W24	1 Part Epoxy 200°C

412H622-625

TRANSITION,
SIDE BREAKOUT,
LOW PROFILE



EXPANDED, AS SUPPLIED, PART

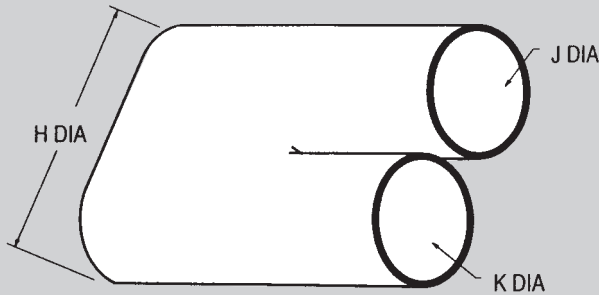

This style provides connector cable strain relief and is used in conjunction with a circular grooved adapter

FULLY RECOVERED PART (AFTER HEATING)

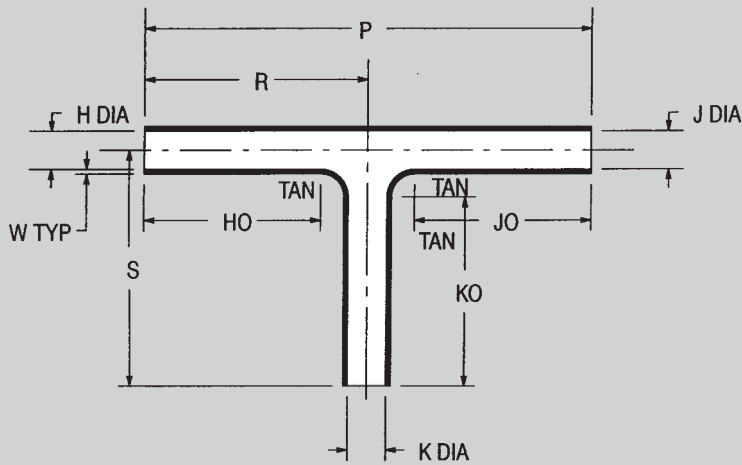

1. All dimensions are in inches – all angles in degrees.
2. Dimensions in table:
X = Expanded (minimum);
R = Recovered (maximum)
3. Colour: Black

Part Number	H DIA		HO, JO & KO ±10% R	W NOM R	P NOM R	R & S NOM R	J & K DIA	
	MIN X	MAX R					MIN X	MAX R
412H622	0.78	0.26	1.00	0.04	3.18	1.59	0.52	0.26
412H623	1.35	0.45	1.62	0.05	4.74	2.37	0.90	0.45
412H624	2.37	0.79	2.50	0.06	6.92	3.46	1.58	0.79
412H625	3.28	1.31	3.50	0.07	9.54	4.77	2.16	1.31

MATERIALS AVAILABLE

- 6 Flexible modified Polyolefin
- 8 Flexible cross-linked modified fluoroelastomer blend
- *-9 Flexible modified Elastomer

ADHESIVE OPTIONS

Adhesive (Part Numbers)	Factory Applied	Description
TSA-200	-200	Thermoset 125°C
TTS-250	-250	Thermoplastic 80°C
TTS-450	-450	Thermoplastic 120°C
W24	W24	1 Part Epoxy 200°C

492H412-415

TRANSITION,
1 TO 2 CABLES, Y,
LOW PROFILE

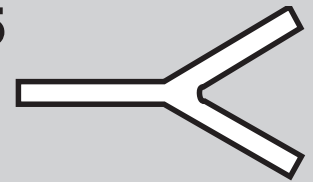

This style provides strain relief, sealing and mechanical protection on cable harness breakouts or transitions.

EXPANDED, AS SUPPLIED, PART

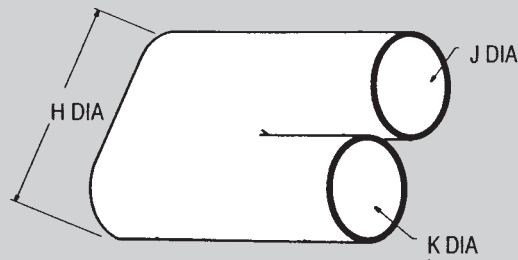

FULLY RECOVERED PART (AFTER HEATING)

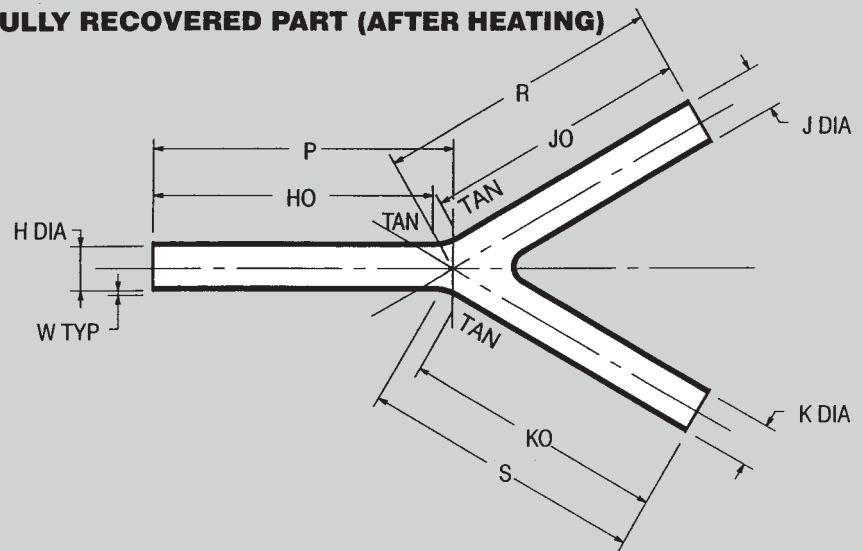

1. All dimensions are in inches – all angles in degrees.
2. Dimensions in table:
X = Expanded (minimum);
R = Recovered (maximum)
3. Colour: Black

Part Number	H DIA		HO, JO & KO ±15% R	W NOM R	P, R & S NOM R	J & K DIA	
	MIN X	MAX R				MIN X	MAX R
492H412	0.78	0.26	1.00	0.04	1.60	0.52	0.26
492H413	1.35	0.45	1.62	0.05	2.48	0.90	0.45
492H414	2.37	0.79	2.50	0.06	3.73	1.58	0.79
492H415	3.28	1.31	3.50	0.07	5.27	2.16	1.31
492H414-01	2.37	0.79	1.25	0.06	2.48	1.58	0.79
492H415-01	3.28	1.31	1.96	0.07	3.73	2.16	1.31

MATERIALS AVAILABLE

- 6 Flexible modified Polyolefin
- 8 Flexible cross-linked modified fluoroelastomer blend
- *-9 Flexible modified Elastomer

ADHESIVE OPTIONS

Adhesive (Part Numbers)	Factory Applied	Description
TSA-200	-200	Thermoset 125°C
TTS-250	-250	Thermoplastic 80°C
TTS-450	-450	Thermoplastic 120°C
W24	W24	1 Part Epoxy 200°C

573H532-535

TRANSITION,
1 TO 3 CABLES,
LOW PROFILE

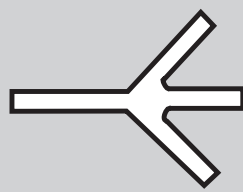

EXPANDED, AS SUPPLIED, PART

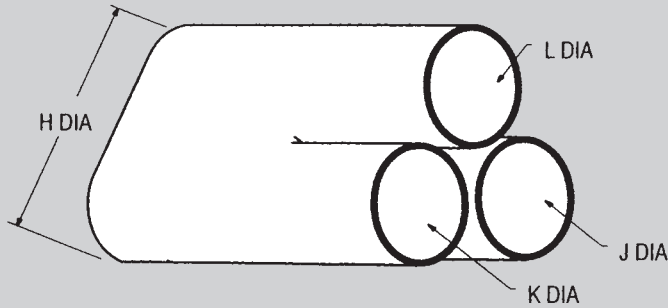

FULLY RECOVERED PART (AFTER HEATING)

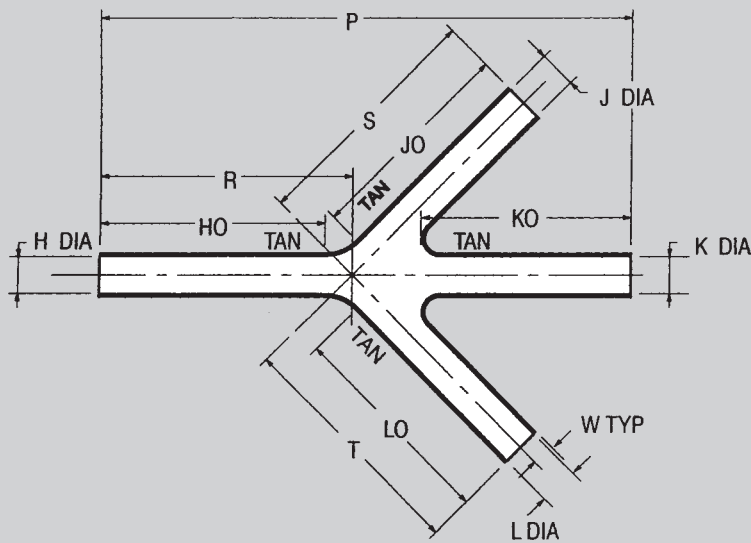

This style provides strain relief, sealing and mechanical protection on cable harness breakouts or transitions.

1. All dimensions are in inches – all angles in degrees.
2. Dimensions in table:
X = Expanded (minimum);
R = Recovered (maximum)
3. Colour: Black

Part Number	H DIA		HO, JO, KO & LO ±15% R	P NOM R	R, S & T NOM R	W NOM R	J, K & L DIA	
	MIN X	MAX R					MIN X	MAX R
573H532	0.78	0.26	1.00	3.38	1.69	0.04	0.52	0.26
573H533	1.35	0.45	1.62	5.34	2.67	0.05	0.81	0.45
573H534	2.37	0.79	2.50	8.16	4.08	0.06	1.42	0.79
573H535	3.93	1.31	3.50	11.60	5.80	0.07	2.16	1.31
573H534-01	2.37	0.79	1.09	5.34	2.67	0.06	1.42	0.79
573H535-01	3.93	1.31	1.79	8.16	4.08	0.07	2.16	1.31

MATERIALS AVAILABLE

- 6 Flexible modified Polyolefin
- 8 Flexible cross-linked modified fluoroelastomer blend
- *-9 Flexible modified Elastomer

ADHESIVE OPTIONS

Adhesive (Part Numbers)	Factory Applied	Description
TSA-200	-200	Thermoset 125°C
TTS-250	-250	Thermoplastic 80°C
TTS-450	-450	Thermoplastic 120°C
W24	W24	1 Part Epoxy 200°C

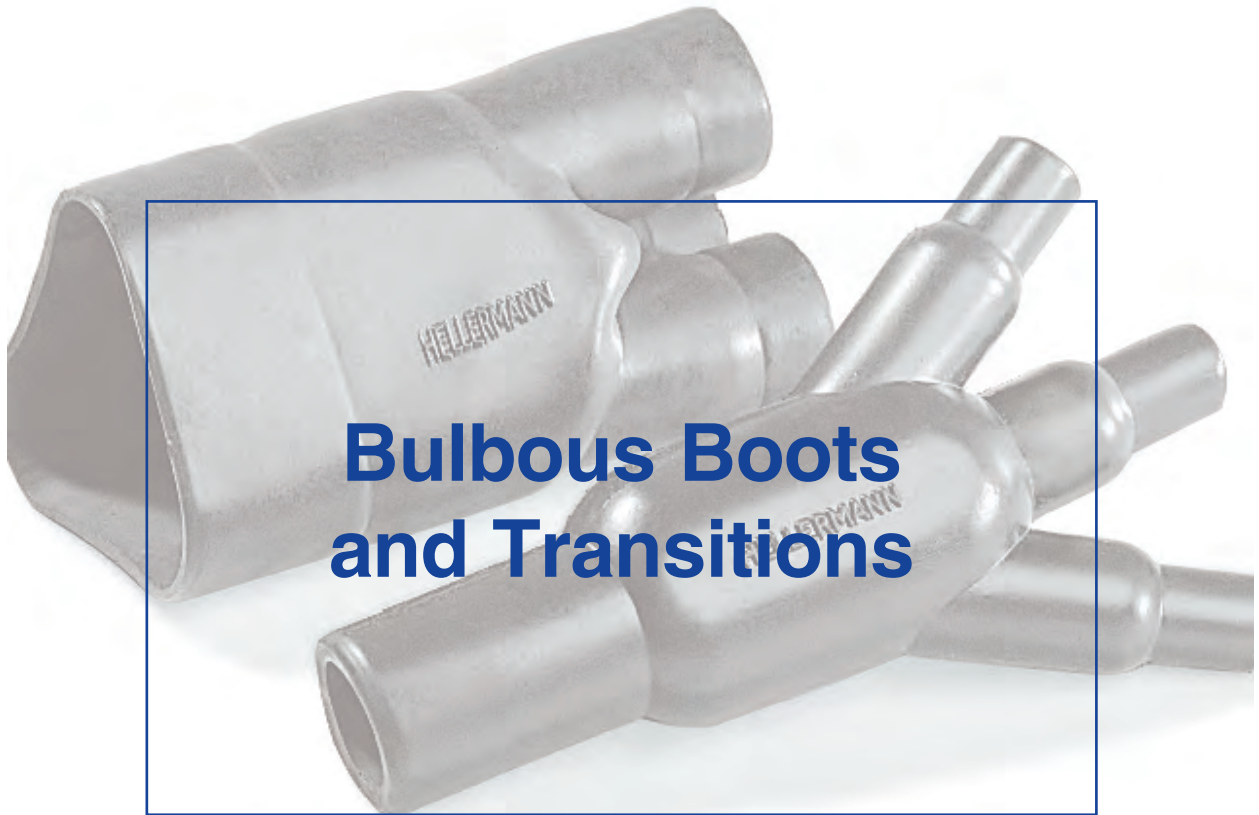

**Bulbous Boots
and Transitions**

150 SERIES

BOTTLE SHAPES WITH RIB - VG STYLE



This style is used in conjunction with a circular grooved adaptor, providing strain relief and environmental sealing.

For VG shapes according to T07 add 'P' after Hellermann part number.

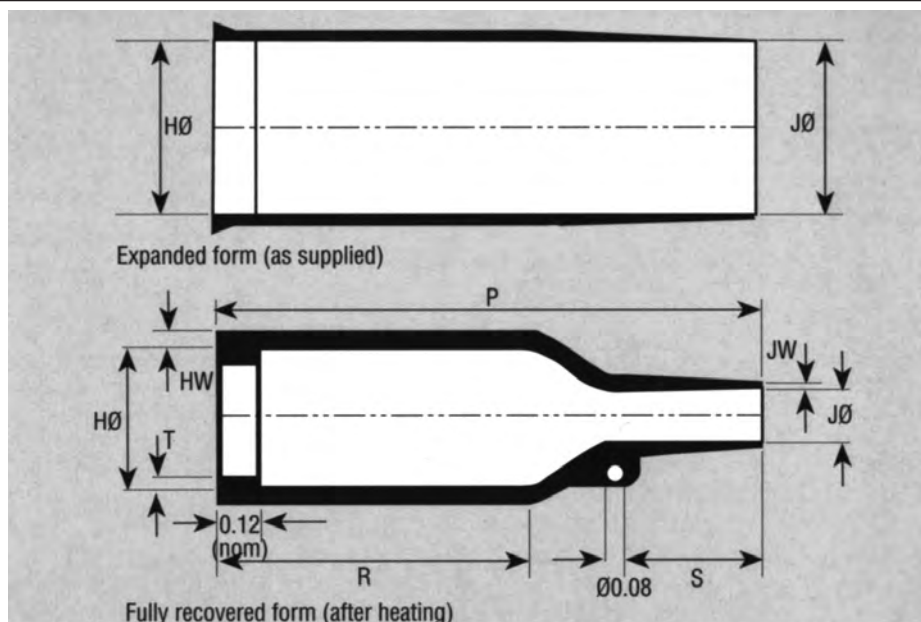

Dimensions apply to all materials unless otherwise indicated and are in inches.

VG Part No.	Hellermann Part No.	Expanded (Min)				Rec'd (Max)		Recovered dimensions fully shrunk					
		H	H -H matl	J	J -H matl	H	J	P ±10%	R ±10%	S nom	T ±20%	HW ±20%	JW ±20%
VG 95343 T06 B001A	* 152-42	0.94	0.94	0.94	0.94	0.41	0.24	1.50	0.82	0.39	0.04	0.06	0.02
VG 95343 T06 B 002A	* 153-42	0.98	0.98	0.35	0.35	0.55	0.14	2.17	1.10	0.63	0.04	0.07	0.02
VG 95343 T06 B 003A	* 154-42	1.18	1.18	1.18	1.18	0.55	0.24	2.17	1.26	0.51	0.04	0.07	0.04
VG 95343 T06 B 004A	* 155-42	1.22	1.22	1.22	1.22	0.71	0.28	2.64	1.38	0.71	0.04	0.07	0.04
VG 95343 T06 B 005A	* 156-42	1.42	1.42	1.42	1.42	0.89	0.33	3.15	1.65	0.79	0.04	0.08	0.04
VG 95343 T06 C 001A	* 157-43	1.69	1.69	1.69	1.69	1.10	0.39	3.90	2.36	0.79	0.07	0.09	0.04
VG 95343 T06 C 002A	* 158-43	2.36	2.36	2.36	2.36	1.38	0.63	5.12	2.83	1.50	0.07	0.13	0.06
VG 95343 T06 C 003A	* 159-43	2.60	2.60	2.60	2.60	1.77	0.67	6.73	3.54	1.97	0.08	0.15	0.08
VG 95343 T06 C 004A	160-43	3.23	3.19	3.23	3.19	2.28	1.06	8.39	4.45	2.44	0.08	0.15	0.15

Non-standard products with reduced overall lengths

VG 95343 T 06 A 001 A	152-41	0.94	0.94	0.94	0.94	0.41	0.24	1.02	0.35	0.39	0.04	0.06	0.02
VG 95343 T 06 A 002 A	153-41	0.98	0.98	0.98	0.98	0.55	0.14	1.57	0.51	0.63	0.04	0.07	0.02
VG 95343 T 06 A 003 A	154-41	1.18	1.18	1.18	1.18	0.55	0.24	1.69	0.79	0.51	0.04	0.07	0.04
VG 95343 T 06 A 004 A	155-41	1.22	1.22	1.22	1.22	0.71	0.28	1.85	0.59	0.71	0.04	0.07	0.04
VG 95343 T 06 A 005 A	156-41	1.42	1.42	1.42	1.42	0.89	0.33	2.36	0.87	0.79	0.04	0.08	0.04
VG 95343 T 06 A 006 A	157-41	1.69	1.69	1.69	1.69	1.10	0.39	2.36	0.83	0.79	0.07	0.09	0.04
VG 95343 T 06 B 006 A	157-42	1.69	1.69	1.69	1.69	1.10	0.39	3.11	1.61	0.79	0.07	0.09	0.04
VG 95343 T 06 A 007 A	158-41	2.36	2.36	2.36	2.36	1.38	0.63	3.54	1.26	1.50	0.07	0.13	0.06
VG 95343 T 06 B 007 A	158-42	2.36	2.36	2.36	2.36	1.38	0.63	4.33	2.05	1.50	0.07	0.13	0.06
VG 95343 T 06 A 008 A	159-41	2.60	2.60	2.60	2.60	1.77	0.67	5.12	1.97	1.97	0.08	0.15	0.08
VG 95343 T 06 B 008 A	159-42	2.60	2.60	2.60	2.60	1.77	0.67	5.91	2.76	1.97	0.08	0.15	0.08
VG 95343 T 06 A 009 A	160-41	3.23	3.19	3.23	3.19	2.28	1.06	5.39	1.46	2.44	0.08	0.15	0.15
VG 95343 T 06 B 009 A	160-42	3.23	3.19	3.23	3.19	2.28	1.06	6.22	2.28	2.44	0.08	0.15	0.15

MATERIALS AVAILABLE

Reference	Specification	Description
J	* MIL-I-81765/TYPE II	Flexible modified polyolefin
B7	* MIL-I-81765/TYPE I	Semi-rigid flame retarded polyolefin
G	* VG 95343 PART 6	Fluid resistant elastomer
H	* NAVSEA 5617649	Flexible limited fire hazard material

ADHESIVE COATING OPTIONS

Reference	Description
WM250	General purpose hot melt +80°C
W8	High performance hot melt +105°C
W24	1 Part Epoxy 200°C

* Standard products and materials.

For ordering procedure – refer to page 5

100 SERIES BOTTLE SHAPES WITH RIB MIL STYLE

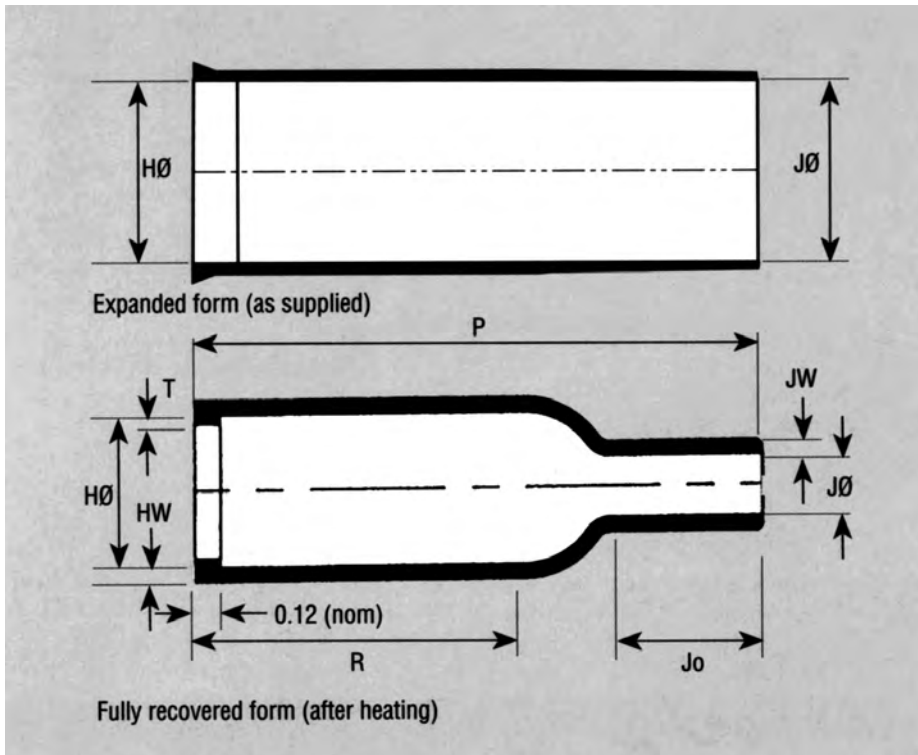

This style is used in conjunction with a circular grooved adaptor providing strain relief and environmental sealing.

Dimensions apply to all materials unless otherwise indicated and are in inches.

MIL Spec No.	Hellermann Part No.	Expanded (Min)				Rec'd (Max)		Recovered dimensions fully shrunk					
		H	H -H matl	J	J -H matl	H	J	P $\pm 10\%$	R $\pm 10\%$	Jo $\pm 10\%$	HW $\pm 10\%$	JW $\pm 10\%$	T $\pm 10\%$
—	1037-4	0.35	N/A	0.16	N/A	0.38	0.07	0.75	0.35	0.18	0.04	0.02	0.02
—	1030-4	0.47	N/A	0.24	N/A	0.38	0.08	0.75	0.31	0.18	0.04	0.02	0.02
—	1031-4	0.47	N/A	0.24	N/A	0.38	0.08	0.59	0.16	0.18	0.04	0.02	0.02
—	1009-1	0.35	0.35	0.16	0.16	0.22	0.13	1.06	0.55	0.29	0.04	0.02	0.04
—	113-4	0.42	0.42	0.18	0.18	0.31	0.08	1.00	0.57	0.18	0.05	0.05	0.04
—	104-4	0.65	0.65	0.65	0.65	0.31	0.15	1.00	0.56	0.27	0.05	0.05	0.04
MS 3109-11-	* 105-4	0.92	0.92	0.92	0.92	0.41	0.22	1.50	0.90	0.40	0.06	0.06	0.04
MS 3109-12-	106-4	1.22	N/A	1.22	N/A	0.56	0.26	2.17	0.90	0.40	0.06	0.06	0.04
MS 3109-13-	* 101-4	1.22	1.22	1.22	1.22	0.70	0.28	2.60	1.50	0.70	0.08	0.08	0.04
MS 3109-14-	102-4	1.42	1.42	1.42	1.42	0.88	0.33	3.15	1.70	0.70	0.07	0.07	0.04
MS 3109-15-	* 103-4	1.68	1.68	1.68	1.68	1.11	0.39	3.90	2.50	0.86	0.08	0.08	0.07
MS 3109-16	* 107-4	2.04	2.04	2.04	2.04	1.38	0.62	4.90	2.60	1.60	0.12	0.12	0.07
MS 3109-17	118-4	2.60	2.60	2.60	2.60	1.75	0.80	6.32	3.60	1.90	0.15	0.15	0.08
MS 3109-18	119-4	3.40	3.40	3.40	3.40	2.25	1.05	8.25	4.65	2.40	0.18	0.18	0.08

MATERIALS AVAILABLE

Reference	Specification	Description
J	* MIL-I-81765/TYPE II	Flexible modified polyolefin
B7	* MIL-I-81765/TYPE I	Semi-rigid flame retarded polyolefin
G	VG 95343 PART 6	Fluid resistant elastomer
H	NAVSEA 5617649	Flexible limited fire hazard material

ADHESIVE COATING OPTIONS

Reference	Description
WM250	General purpose hot melt +80°C
W8	High performance hot melt +105°C
W24	1 Part Epoxy 200°C

*Standard products and material.

100 SERIES

BOTTLE SHAPES

WITHOUT RIB



This style is used for cable strain relief and mechanical protection. Product can be installed on the connector rear thread or plain shaft.

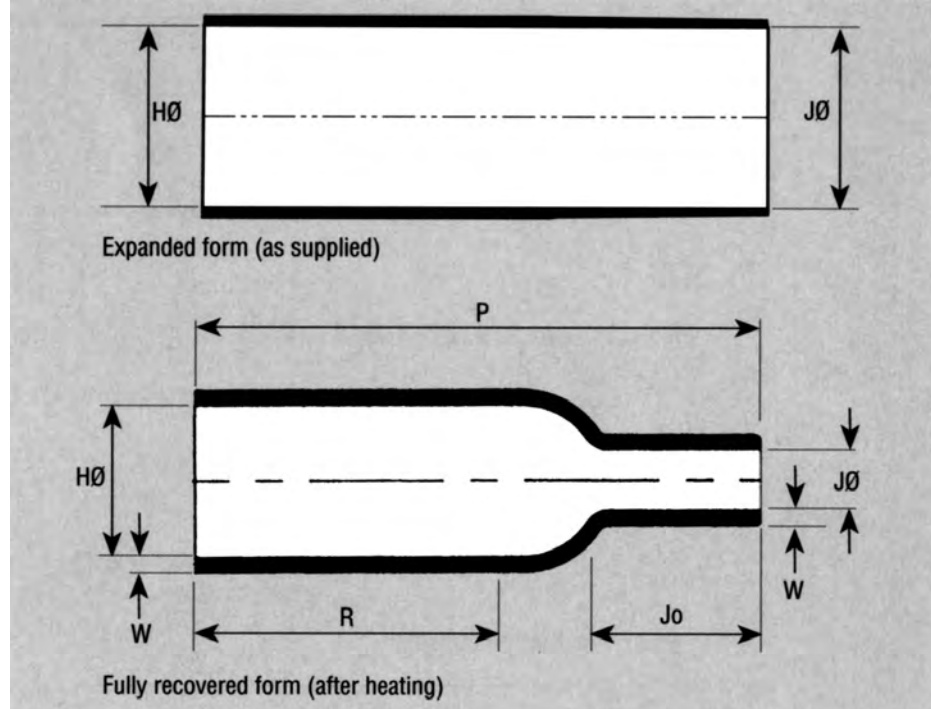

Dimensions apply to all materials unless otherwise indicated and are in inches.

Hellermann Part No.	Expanded (Min)				Recovered (Max)		Recovered dimensions fully shrunk			
	H	H -H matl	J	J -H matl	H	J	P ±10%	R ±10%	Jo ±10%	W ±20%
* 104-1	0.65	0.65	0.65	0.65	0.31	0.15	1.00	0.56	0.27	0.05
* 104-2	0.42	0.33	0.33	0.33	0.31	0.15	1.00	0.56	0.27	0.05
* 105-1	0.92	0.92	0.92	0.92	0.41	0.22	1.50	0.90	0.40	0.06
* 105-2	0.54	0.54	0.46	0.46	0.41	0.22	1.50	0.90	0.40	0.06
* 106-1	1.22	N/A	1.22	N/A	0.56	0.26	2.18	1.04	0.65	0.07
* 106-2	0.76	0.76	0.56	0.56	0.56	0.26	2.18	1.04	0.65	0.07
* 101-1	1.22	1.22	1.22	1.22	0.70	0.28	2.60	1.50	0.70	0.07
* 101-2	0.94	0.94	0.61	0.61	0.70	0.28	2.60	1.50	0.70	0.07
* 102-1	1.42	N/A	1.42	N/A	0.88	0.33	2.90	1.70	0.70	0.07
* 102-2	1.18	1.18	0.71	0.71	0.88	0.33	2.90	1.70	0.70	0.07
* 103-1	1.68	1.68	1.68	1.68	1.11	0.39	3.76	2.13	0.94	0.08
* 103-2	1.49	1.49	0.84	0.84	1.11	0.39	3.76	2.13	0.94	0.08
* 107-1	2.04	2.04	2.04	2.04	1.38	0.62	4.90	2.60	1.60	0.12
* 107-2	1.85	1.85	1.40	1.40	1.38	0.62	4.90	2.60	1.60	0.12
118-1	2.60	2.60	2.60	2.60	1.75	0.80	6.32	3.60	1.90	0.15
119-1	3.40	3.40	3.40	3.40	2.25	1.05	8.25	4.65	2.40	0.18
119-2	3.20	3.20	2.19	2.19	2.25	1.05	8.25	4.65	2.40	0.18

MATERIALS AVAILABLE

Reference	Specification	Description
J	* MIL-I-81765/TYPE II	Flexible modified polyolefin
B7	* MIL-I-81765/TYPE I	Semi-rigid flame retarded polyolefin
G	VG 95343 PART 6	Fluid resistant elastomer
H	NAVSEA 5617649	Flexible limited fire hazard material

ADHESIVE COATING OPTIONS

Reference	Description
WM250	General purpose hot melt +80°C
W8	High performance hot melt +105°C
W24	1 Part Epoxy 200°C

* Standard products and materials.

100 SERIES BOTTLE SHAPES WITHOUT RIB (THICK WALL)

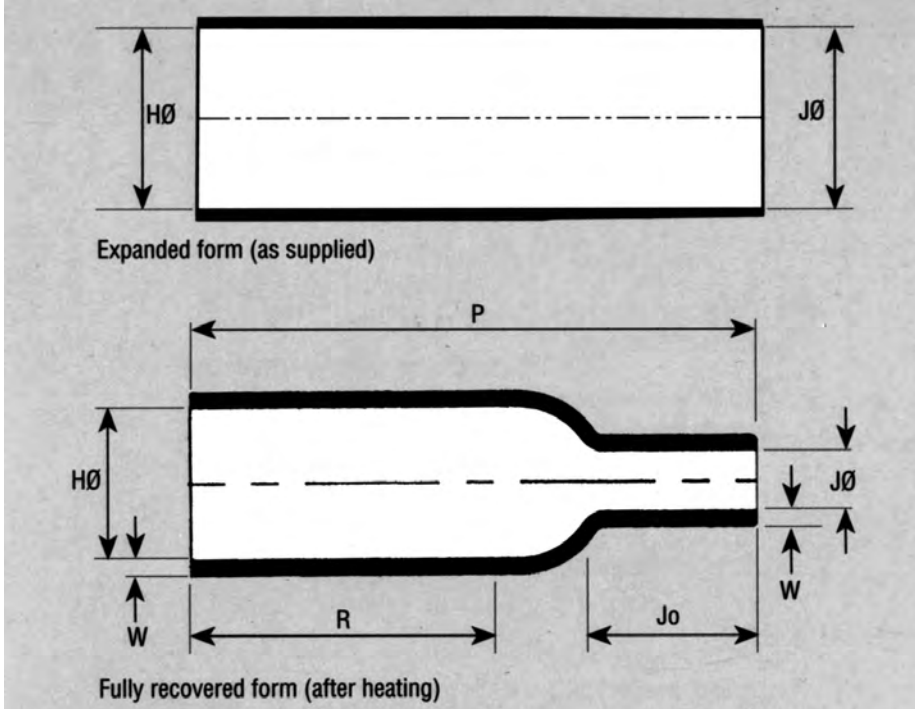

This style is used for cable strain relief and mechanical protection. Product can be installed on the connector rear thread or plain shaft.

Dimensions apply to all materials unless otherwise indicated and are in inches.

Hellermann Part No.	Expanded (Min)				Rec'd (Max)		Recovered dimensions fully shrunk				
	H	H -H matl	J	J -H matl	H	J	P ±10%	R ±10%	Jo ±10%	HW ±20%	JW ±20%
* 113-1	0.42	0.42	0.18	0.18	0.31	0.08	1.00	0.57	0.18	0.05	0.04
* 113-2	0.79	0.79	0.23	0.23	0.31	0.08	1.00	0.57	0.18	0.05	0.04
108-1	0.54	0.54	0.26	0.26	0.41	0.10	1.50	0.90	0.30	0.06	0.04
108-2	1.10	1.10	0.31	0.31	0.41	0.10	1.50	0.90	0.30	0.06	0.04
109-1	0.76	0.76	0.32	0.32	0.56	0.16	2.10	1.40	0.30	0.08	0.05
109-2	1.50	1.50	0.46	0.46	0.56	0.16	2.10	1.40	0.30	0.08	0.05
110-1	0.94	0.94	0.46	0.46	0.70	0.22	2.50	1.50	0.50	0.10	0.06
110-2	2.00	2.00	0.67	0.67	0.70	0.22	2.50	1.50	0.50	0.10	0.06
111-1	1.18	1.18	0.58	0.58	0.88	0.28	3.00	1.70	0.60	0.12	0.07
111-2	2.50	2.50	0.84	0.84	0.88	0.28	3.00	1.70	0.60	0.12	0.07
116-1	2.34	2.34	1.72	1.72	1.75	0.82	6.25	3.60	1.65	0.22	0.18

MATERIALS AVAILABLE

Reference	Specification	Description
J	* MIL-I-81765/TYPE II	Flexible modified polyolefin
B7	* MIL-I-81765/TYPE I	Semi-rigid flame retarded polyolefin
G	VG 95343 PART 6	Fluid resistant elastomer
H	NAVSEA 5617649	Flexible limited fire hazard material

ADHESIVE COATING OPTIONS

Reference	Description
WM250	General purpose hot melt +80°C
W8	High performance hot melt +105°C
W24	1 Part Epoxy 200°C

*Standard products and materials.

120 SERIES

BOTTLE SHAPES
WITHOUT RIB



This style has a long tail providing extended strain relief for small diameter wires.

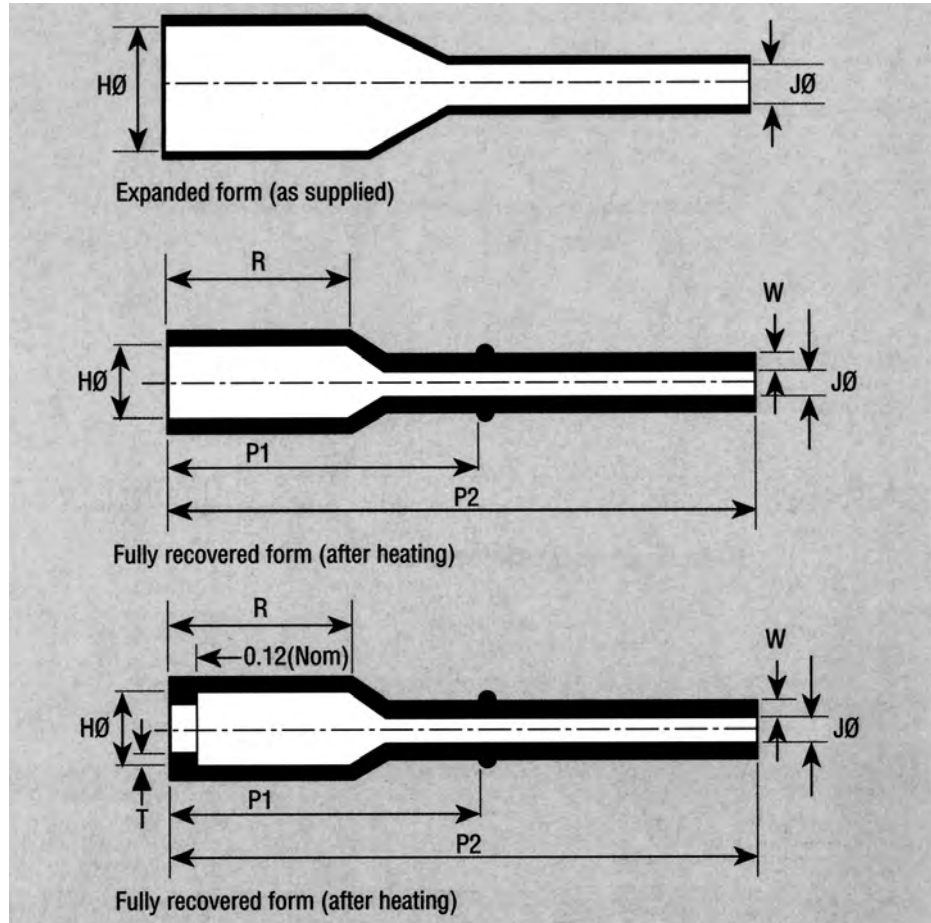

Dimensions apply to all materials unless otherwise indicated and are in inches.

Hellermann Part No.	Expanded (Min)		Recovered (Max)		Recovered dimensions fully shrunk				
	H	J	H	J	P1 ±10%	P2 ±10%	R ±10%	W ±20%	T
* 120-1	0.65	0.40	0.275	0.12	—	2.40	0.75	0.04	—
* 120-2	0.80	0.40	0.275	0.12	—	2.40	0.75	0.04	—
120-3	0.65	0.42	0.275	0.12	1.50	—	0.95	0.051	—
120-41	0.65	0.42	0.275	0.12	1.50	—	0.95	0.051	0.40
120-42	0.65	0.42	0.275	0.12	—	2.40	0.95	0.051	0.40

NOTE: 120-41 and 42 are with end ribs

MATERIALS AVAILABLE

Reference	Specification	Description
J	* MIL-I-81765/TYPE II	Flexible modified polyolefin
B7	* MIL-I-81765/TYPE I	Semi-rigid flame retarded polyolefin
G	* VG 95343 PART 6	Fluid resistant elastomer
H	NAVSEA 5617649	Flexible limited fire hazard material

ADHESIVE COATING OPTIONS

Reference	Description
WM250	General purpose hot melt +80°C
W8	High performance hot melt +105°C
W24	1 Part Epoxy 200°C

* Standard products and materials.

For ordering procedure – refer to page 5

130 SERIES

LONG OUTLET SHAPES

LOW PROFILE VG/MIL

STYLE WITH RIB

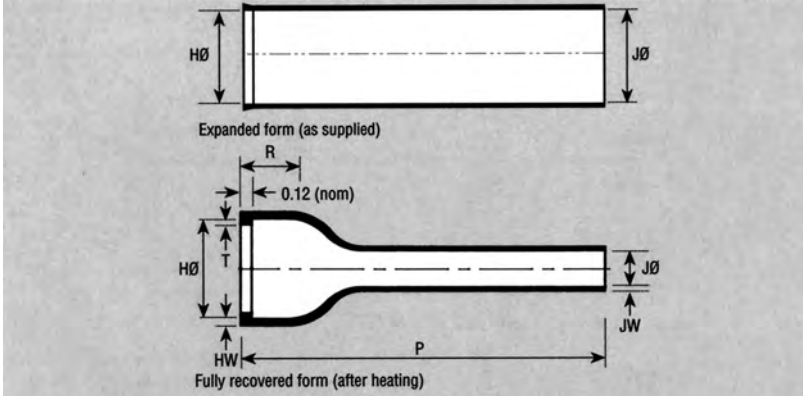

This style is low profile and lightweight. Typically used on airborne harnesses. The rib locates on circular backshell.

For VG shapes according to T07 add 'P' after Hellermann part number. Dimensions apply to all materials unless otherwise indicated and are in inches.

VG Part No.	Hellermann Part No.	Expanded (Min)		Recovered (Max)		Recovered dimensions fully shrunk				
		H	J	H	J	P ±10%	R ±10%	T ±10%	HW ±20%	JW ±20%
VG 95343 T06 D001A	* 129-1	0.87	0.87	0.47	0.26	2.99	0.47	0.04	0.06	0.04
VG 95343 T06 D002A	* 130-1	0.89	0.89	0.59	0.30	3.27	0.47	0.04	0.06	0.04
VG 95343 T06 D003A	* 131-1	1.14	1.14	0.75	0.33	3.50	0.47	0.04	0.07	0.04
VG 95343 T06 D004A	* 132-1	1.34	1.34	0.91	0.39	4.02	0.47	0.04	0.07	0.04
VG 95343 T06 D005A	* 133-1	1.46	1.46	1.18	0.43	4.25	0.55	0.07	0.08	0.04
VG 95343 T06 D006A	* 134-1	1.71	1.71	1.34	0.47	4.49	0.59	0.07	0.08	0.04
VG 95343 T06 D007A	135-1	1.97	1.97	1.61	0.57	4.65	0.59	0.07	0.09	0.06
VG 95343 T06 D008A	136-1	2.46	2.46	1.85	0.71	4.76	0.63	0.08	0.10	0.06
VG 95343 T06 D009A	138-1	2.72	2.72	2.36	0.79	5.00	0.63	0.08	0.10	0.06
VG 95343 T06 D010A	187-1	3.21	3.21	2.64	0.91	5.24	0.63	0.08	0.10	0.06

MIL Spec. Part No.										
MS3109-01	* 129-4	0.88	0.88	0.45	0.25	4.17	0.46	0.04	0.06	0.04
MS3109-02	* 130-4	1.01	1.01	0.59	0.29	4.77	0.48	0.04	0.06	0.04
MS3109-03	* 131-4	1.16	1.16	0.74	0.33	5.46	0.48	0.04	0.07	0.04
—	132-2	1.34	1.34	0.90	0.38	1.38	0.48	0.04	0.07	0.04
—	132-3	1.34	1.34	0.82	0.35	2.36	0.48	0.04	0.07	0.04
MS3109-04	* 132-4	1.34	1.34	0.90	0.38	6.28	0.48	0.04	0.07	0.04
—	133-2	1.47	1.47	1.06	0.37	1.85	0.55	0.06	0.08	0.04
—	133-3	1.47	1.47	1.06	0.37	2.36	0.55	0.06	0.08	0.04
MS3109-05	* 133-4	1.47	1.47	1.16	0.41	7.00	0.55	0.06	0.08	0.04
MS3109-06	* 134-4	1.72	1.72	1.34	0.48	8.00	0.60	0.06	0.08	0.04
—	135-2	1.97	1.97	1.48	0.51	1.73	0.60	0.06	0.09	0.06
MS3109-07	135-4	1.97	1.97	1.62	0.56	7.99	0.60	0.06	0.09	0.06
—	136-2	2.76	2.76	1.69	0.69	4.92	0.63	0.08	0.10	0.06
MS3109-08	136-4	2.47	2.47	1.85	0.69	8.00	0.63	0.08	0.10	0.06
MS3109-09	138-4	2.73	2.73	2.15	0.70	8.00	0.63	0.08	0.10	0.06
MS3109-10	187-4	3.22	3.22	2.41	0.82	8.00	0.63	0.08	0.10	0.06

MATERIALS AVAILABLE		
Reference	Specification	Description
J	* MIL-I-81765/TYPE II	Flexible modified polyolefin
B7	* MIL-I-81765/TYPE I	Semi-rigid flame retarded polyolefin
G	* VG 95343 PART 6	Fluid resistant elastomer
H	NAVSEA 5617649	Flexible limited fire hazard material

ADHESIVE COATING OPTIONS	
Reference	Description
WM250	General purpose hot melt +80°C
W8	High performance hot melt +105°C
W24	1 Part Epoxy 200°C

*Standard products and materials.

140 SERIES

LONG OUTLET

SHAPES WITHOUT RIB



This style is low profile, lightweight with extended strain relief.



Expanded form (as supplied)

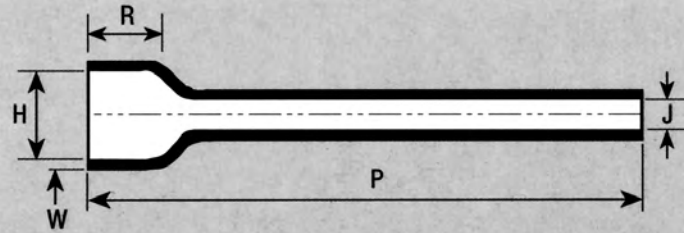

Fully recovered form (after heating)

Dimensions apply to all materials unless otherwise indicated and are in inches.

Hellermann Part No.	Expanded (Min)		Recovered (Max)		Recovered dimensions fully shrunk		
	H	J	H	J	P ±10%	R ±10%	W ±20%
146-1	0.79	0.79	0.57	0.21	5.00	0.62	0.08
146-2	0.88	0.40	0.57	0.21	5.00	0.62	0.08
148-1	1.20	1.20	0.71	0.31	5.75	0.62	0.09
148-2	1.20	0.60	0.71	0.31	5.75	0.62	0.09
149-1	1.62	1.62	0.86	0.40	6.38	0.88	0.09
150-1	2.05	2.05	1.22	0.50	7.06	0.88	0.10

MATERIALS AVAILABLE

Reference	Specification	Description
J	MIL-I-81765/TYPE II	Flexible modified polyolefin
B7	MIL-I-81765/TYPE I	Semi-rigid flame retarded polyolefin
G	VG 95343 PART 6	Fluid resistant elastomer
H	NAVSEA 5617649	Flexible limited fire hazard material

ADHESIVE COATING OPTIONS

Reference	Description
WM250	General purpose hot melt +80°C
W8	High performance hot melt +105°C
W24	1 Part Epoxy 200°C

For ordering procedure – refer to page 5

160 SERIES

BOTTLE SHAPES WITHOUT RIB

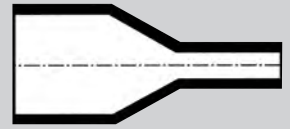

This style is a straight boot used for cable strain relief and environmental protection.

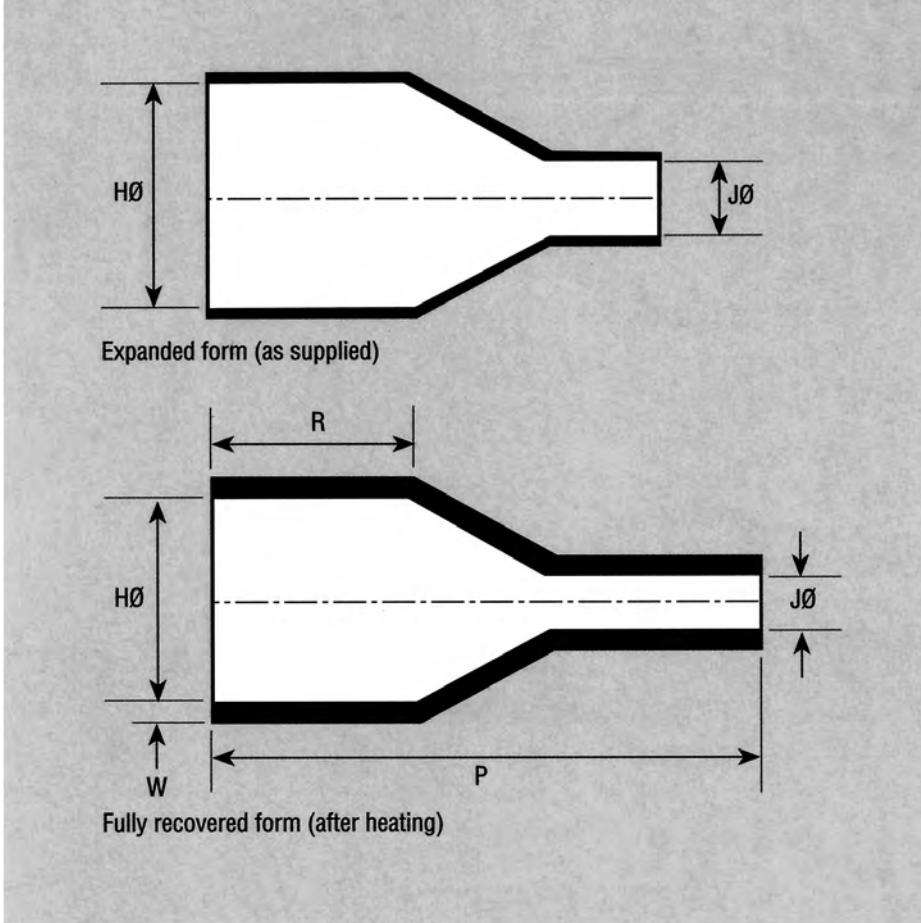

Dimensions apply to all materials unless otherwise indicated and are in inches.

Hellermann Part No.	Expanded (Min)		Recovered (Max)		Recovered dimensions fully shrunk		
	H	J	H	J	P ±10%	R ±10%	W ±20%
162-1	0.87	0.35	0.56	0.16	1.53	0.62	0.07
169-1	0.88	0.31	0.70	0.22	2.00	1.08	0.11
169-2	1.40	0.34	0.70	0.22	2.00	1.08	0.11

MATERIALS AVAILABLE		
Reference	Specification	Description
J	MIL-I-81765/TYPE II	Flexible modified polyolefin
B7	MIL-I-81765/TYPE I	Semi-rigid flame retarded polyolefin
G	VG 95343 PART 6	Fluid resistant elastomer
H	NAVSEA 5617649	Flexible limited fire hazard material

ADHESIVE COATING OPTIONS	
Reference	Description
WM250	General purpose hot melt +80°C
W8	High performance hot melt +105°C
W24	1 Part Epoxy 200°C

For ordering procedure – refer to page 5

170 SERIES

BOTTLE SHAPES WITH RIB-VG STYLE

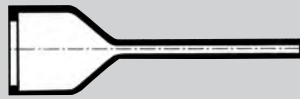

This style provides cable strain relief in applications of partially loaded connectors, resulting in small cable diameters.

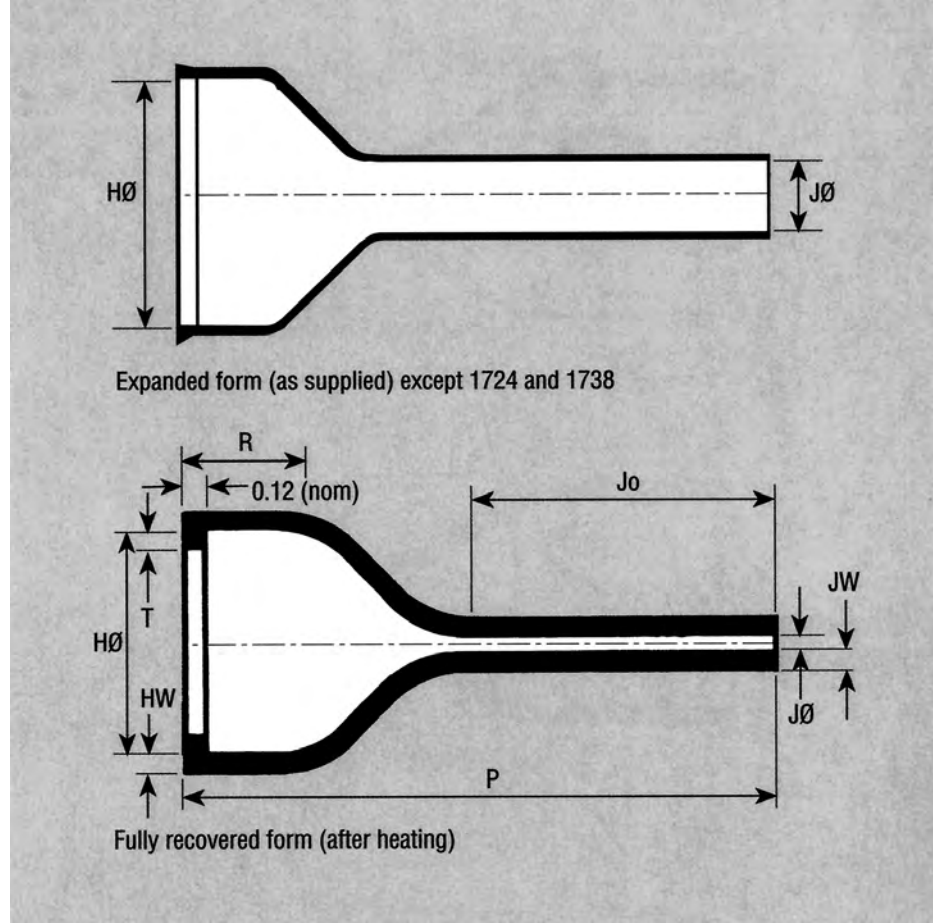

Dimensions apply to all materials unless otherwise indicated and are in inches

VG Part No.	Hellermann Part No.	Expanded (Min)		Recovered (Max)		Recovered dimensions fully shrunk					
		H	J	H	J	P ±10%	R ±10%	T ±10%	Jo ±10%	HW ±20%	JW ±20%
—	1724-1	0.79	0.79	0.65	0.18	1.65	0.79	0.00	0.39	0.04	0.04
—	1738-1	0.79	0.79	0.65	0.18	1.26	0.39	0.00	0.87	0.04	0.04
VG 95343 T06 D011A	* 176-1	0.76	0.25	0.51	0.08	2.37	0.46	0.04	1.48	0.06	0.04
—	176-2	0.76	0.25	0.51	0.08	1.18	0.46	0.04	0.29	0.06	0.04
—	* 176-3	0.98	0.16	0.51	0.08	1.77	0.46	0.04	1.48	0.06	0.04
—	176-4	0.76	0.25	0.51	0.08	2.37	0.46	0.04	1.48	0.06	0.04
VG 95343 T06 D012A	177-1	1.03	0.30	0.75	0.10	2.92	0.48	0.04	1.77	0.07	0.04
VG 95343 T06 D013A	178-1	1.35	0.38	1.02	0.12	3.32	0.48	0.04	2.01	0.07	0.04
VG 95343 T06 D014A	179-1	1.72	0.45	1.34	0.14	3.92	0.48	0.07	2.36	0.07	0.04

NOTE: 1724 and 1738 are without end ribs.

MATERIALS AVAILABLE

Reference	Specification	Description
J	* MIL-I-81765/TYPE II	Flexible modified polyolefin
B7	* MIL-I-81765/TYPE I	Semi-rigid flame retarded polyolefin
G	* VG 95343 PART 6	Fluid resistant elastomer
H	NAVSEA 5617649	Flexible limited fire hazard material

ADHESIVE COATING OPTIONS

Reference	Description
WM250	General purpose hot melt +80°C
W8	High performance hot melt +105°C
W24	1 Part Epoxy 200°C

* Standard products and materials.

For ordering procedure – refer to page 5

190 SERIES

BOTTLE SHAPES WITH EXTERNAL RIBS VG-STYLE

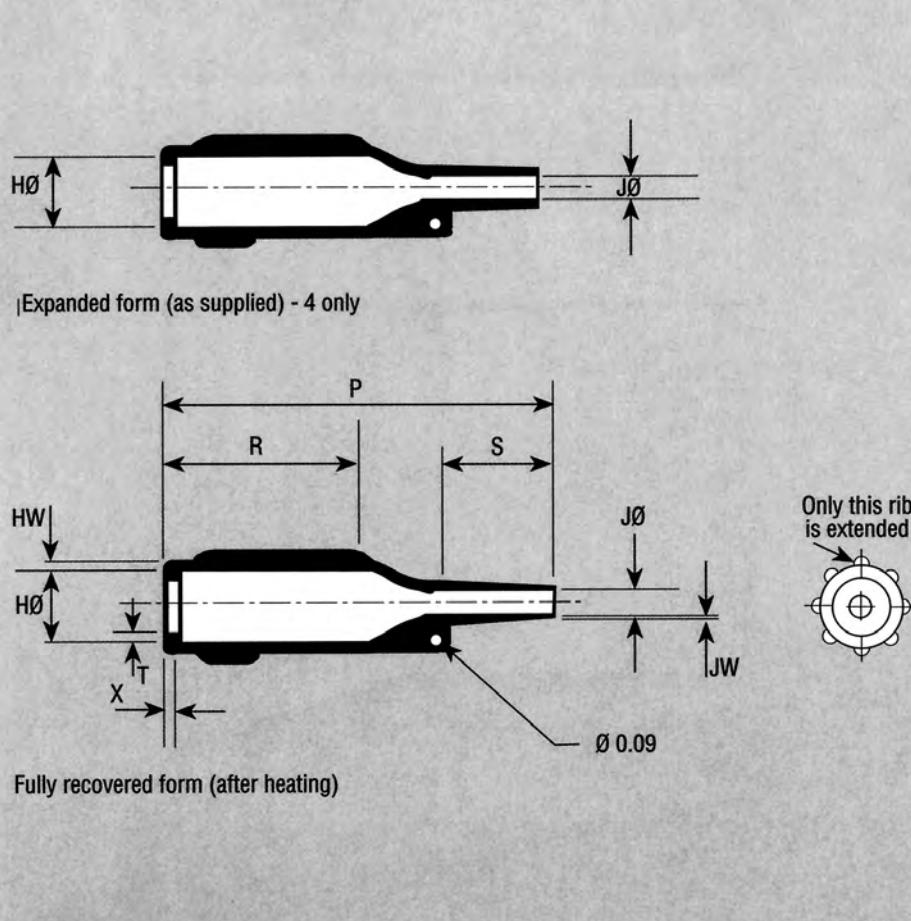

Developed specifically for small audio connectors. External Ribs improve grip.

Dimensions apply to all materials unless otherwise indicated and are in inches.

VG Part No.	Hellermann Part No.	Expanded (Min)		Recovered (Max)		Recovered dimensions fully shrunk						
		H	J	H	J	P ±10%	R ±10%	S ±10%	T ±10%	X nom	HW ±20%	JW ±20%
VG 95343 T06 A010A	199-4	0.69	0.28	0.55	0.17	2.76	1.38	0.79	0.04	0.06	0.07	0.02
-	199-6	0.73	0.73	0.55	0.17	2.76	1.38	0.79	0.04	0.06	0.07	0.02

MATERIALS AVAILABLE

Reference	Specification	Description
J	MIL-I-81765/TYPE II	Flexible modified polyolefin
B7	MIL-I-81765/TYPE I	Semi-rigid flame retarded polyolefin
G *	VG 95343 PART 6	Fluid resistant elastomer
H	NAVSEA 5617649	Flexible limited fire hazard material

ADHESIVE COATING OPTIONS

Reference	Description
WM250	General purpose hot melt +80°C
W8	High performance hot melt +105°C
W24	1 Part Epoxy 200°C

* Standard material.

For ordering procedure – refer to page 5

200 SERIES

2-WAY OUTLET
SHAPES LOW
PROFILE

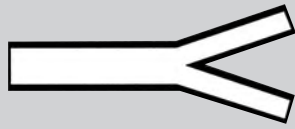

This style provides cable sealing strain relief and mechanical protection.

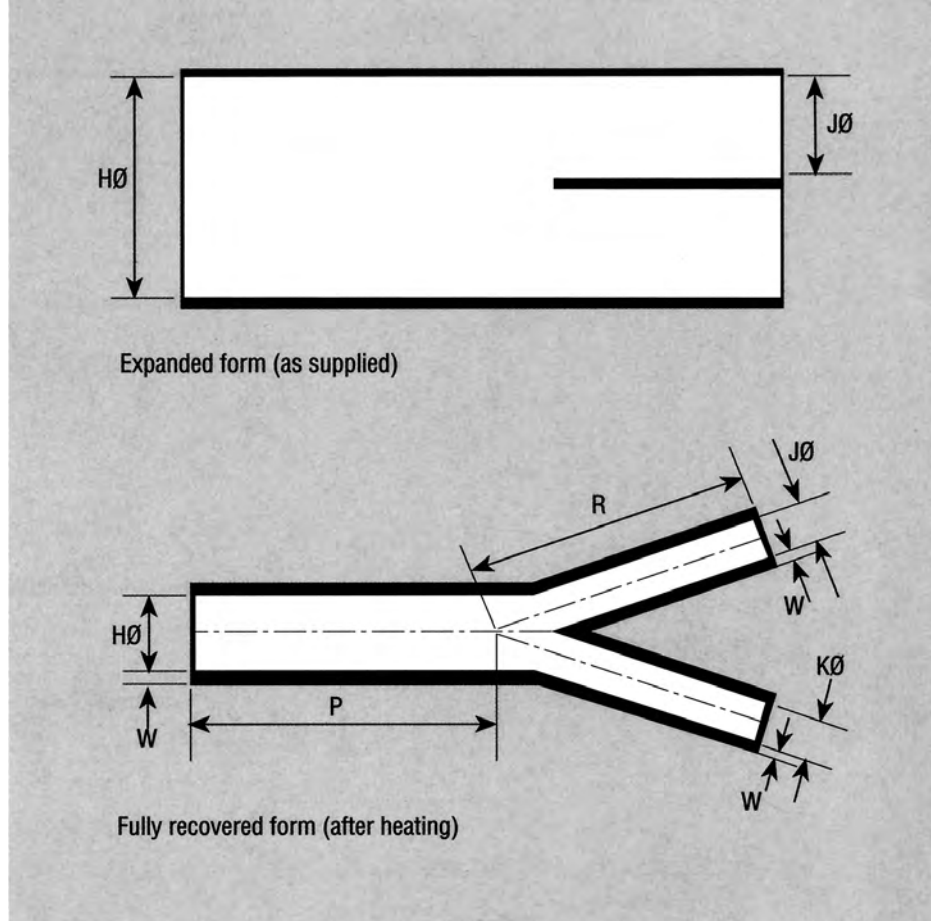

Dimensions apply to all materials unless otherwise indicated and are in inches.

Hellermann Part No.	Expanded (Min)			Recovered (Max)			Rec'd dimensions fully shrunk		
	H	J	K	H	J	K	P ±10%	R ±10%	W ±20%
201-1	0.75	0.55	0.55	0.37	0.25	0.25	2.00	1.20	0.06
201-3	1.00	0.55	0.55	0.37	0.25	0.25	2.00	1.20	0.06
202-1	0.75	0.30	0.30	0.37	0.15	0.15	2.00	1.20	0.06
202-2	0.79	0.49	0.49	0.37	0.15	0.15	2.00	1.20	0.06
202-3	0.96	0.63	0.63	0.37	0.15	0.15	2.00	1.20	0.06

MATERIALS AVAILABLE

Reference	Specification	Description
J	MIL-I-81765/TYPE II	Flexible modified polyolefin
B7	MIL-I-81765/TYPE I	Semi-rigid flame retarded polyolefin
G	VG 95343 PART 6	Fluid resistant elastomer
H	NAVSEA 5617649	Flexible limited fire hazard material

ADHESIVE COATING OPTIONS

Reference	Description
WM250	General purpose hot melt +80°C
W8	High performance hot melt +105°C
W24	1 Part Epoxy 200°C

For ordering procedure – refer to page 5

200 SERIES

2-WAY OUTLET SHAPES - VG STYLE

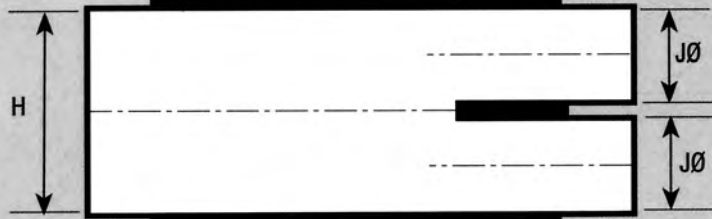

Expanded form (as supplied)

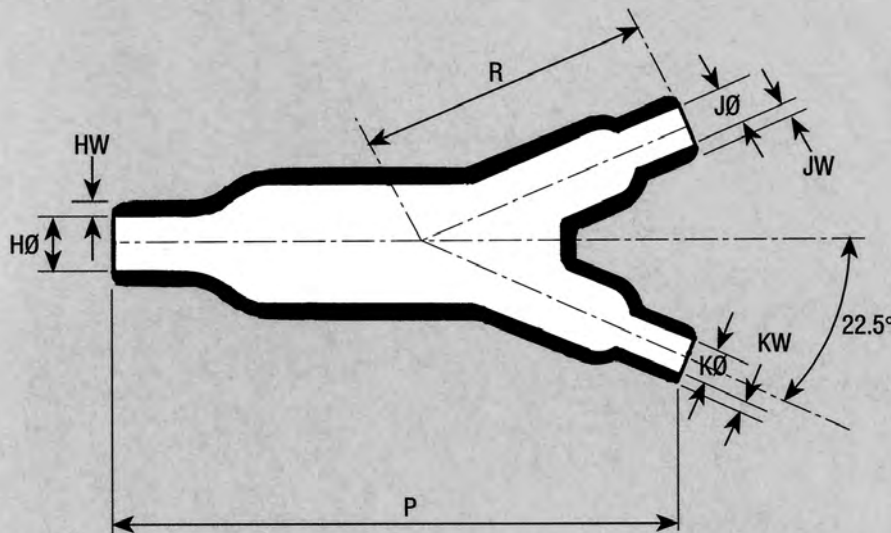

Fully recovered form (after heating)

This style provides cable sealing, strain relief and mechanical protection.

For VG shapes according to T09 add 'P' after Hellermann part number.

Dimensions apply to all materials unless otherwise indicated and are in inches.
H Expanded is maximum width not diameter.

VG Part No.	Hellermann Part No.	Expanded (Min)				Recovered (Max)		Recovered dimensions fully shrunk			
		H	H -H Matl	J,K	J,K -H Matl	H	J,K	P ±10%	R ±10%	HW ±30%	JW, KW ±30%
	* 227-1	0.52	0.52	0.26	0.26	0.15	0.10	1.61	0.76	0.08	0.04
VG 95343 T08 C001A	* 206-1	0.51	0.51	0.28	0.28	0.24	0.12	1.61	0.75	0.06	0.04
	* 213-1	0.68	0.68	0.44	0.44	0.31	0.31	3.27	2.52	0.09	0.04
	213-2	1.57	N/A	1.25	N/A	0.31	0.31	3.27	2.52	0.09	0.09
VG 95343 T08 C005A	212-1	0.57	0.57	0.33	0.33	0.31	0.22	5.35	2.48	0.10	0.08
VG 95343 T08 C002A	* 203-1	1.06	1.06	0.51	0.51	0.47	0.24	3.15	1.69	0.10	0.06
VG 95343 T08 C003A	* 204-1	1.54	1.54	1.06	1.06	0.71	0.47	5.16	3.19	0.12	0.10

MATERIALS AVAILABLE

Reference	Specification	Description
J	* MIL-I-81765/TYPE II	Flexible modified polyolefin
B7	* MIL-I-81765/TYPE I	Semi-rigid flame retarded polyolefin
G	* VG 95343 PART 6	Fluid resistant elastomer
H	NAVSEA 5617649	Flexible limited fire hazard material

ADHESIVE COATING OPTIONS

Reference	Description
WM250	General purpose hot melt +80°C
W8	High performance hot melt +105°C
W24	1 Part Epoxy 200°C

* Standard products and materials.

For ordering procedure – refer to page 5

200 SERIES

2-WAY OUTLET SHAPES IN LINE



This style provides cable sealing strain relief and mechanical protection. Ideal for power and signal applications.

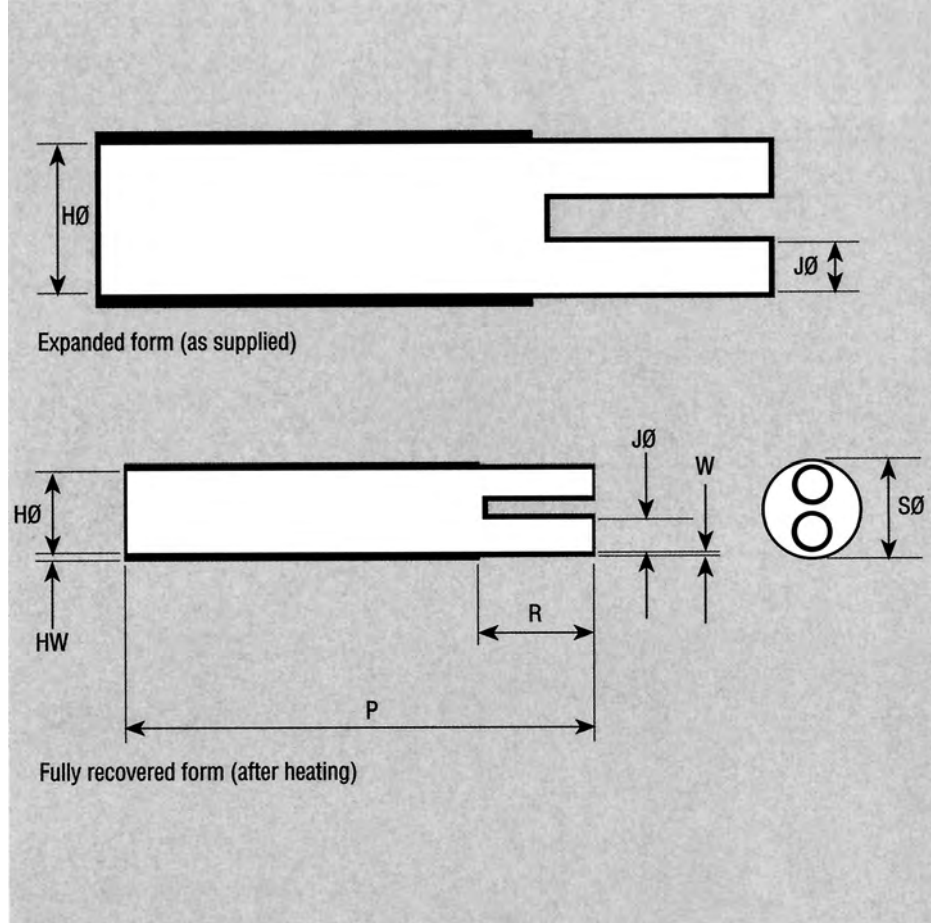

Dimensions apply to all materials unless otherwise indicated and are in inches.

NAVSEA REFERENCE	Hellermann Part No.	Expanded (Min)				Recovered (Max)		Recovered dimensions fully shrunk				
		H	H -H Matl	J	J -H Matl	H	J	P ±10%	R ±10%	S (nom)	HW ±20%	W ±20%
—	223-2	1.30	1.30	0.69	0.69	0.37	0.16	3.70	1.18	0.79	0.06	0.05
IA62-1	* 216-3	0.83	0.83	0.35	0.35	0.37	0.11	3.01	0.79	0.59	0.06	0.06
IA62-2	* 217-2	1.22	1.22	0.59	0.59	0.60	0.17	3.92	1.12	0.75	0.09	0.09
IA62-3	* 218-2	1.97	1.97	0.83	0.83	0.90	0.30	4.69	1.34	1.18	0.13	0.13
—	220-1	1.97	1.97	0.91	0.91	1.10	0.31	6.89	3.94	1.30	0.10	0.10
IA62-4	* 219-2	3.43	3.43	1.69	1.69	1.50	0.50	5.57	1.67	1.73	0.15	0.15
—	221-1	3.62	3.62	1.81	1.81	1.65	0.59	6.89	3.94	1.85	0.10	0.08

MATERIALS AVAILABLE		
Reference	Specification	Description
J	MIL-I-81765/TYPE II	Flexible modified polyolefin
B7	* MIL-I-81765/TYPE I	Semi-rigid flame retarded polyolefin
G	VG 95343 PART 6	Fluid resistant elastomer
H	NAVSEA 5617649	Flexible limited fire hazard material
B8		Semi-rigid polyolefin

ADHESIVE COATING OPTIONS	
Reference	Description
W1	Band lined WM250

* Standard products and material.

300 SERIES

3-WAY OUTLET SHAPES-VG STYLE

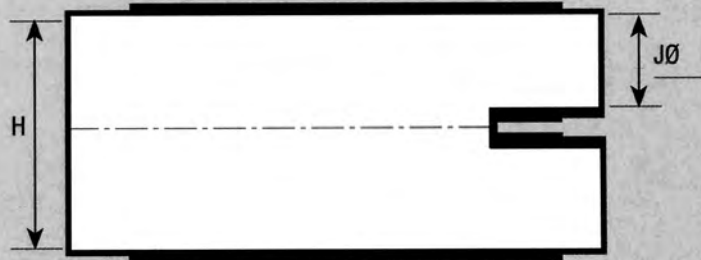
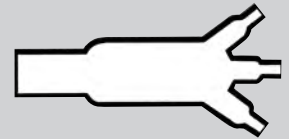

Expanded form (as supplied)

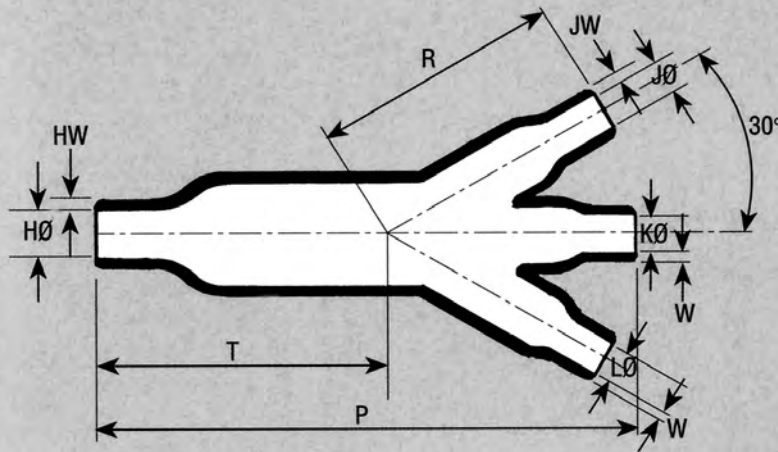

Fully recovered form (after heating)

This style provides cable sealing strain relief and mechanical protection.

Dimensions apply to all materials unless otherwise indicated and are in inches.

VG Part No.	Hellermann Part No.	Expanded (Min)		Recovered (Max)		Recovered dimensions fully shrunk				
		H	J,K,L	H	J,K,L	P ±10%	R ±10%	T ±10%	HW ±20%	W ±20%
—	334-1	0.52	0.26	0.15	0.10	1.82	1.00	0.80	0.08	0.04
VG 95343 T08 D001A	* 306-1	0.51	0.26	0.26	0.14	1.81	0.98	0.83	0.06	0.04
VG 95343 T08 D002A	* 304-1	1.06	0.51	0.53	0.28	3.66	1.97	1.69	0.10	0.06
VG 95343 T08 D003A	* 310-1	1.52	0.75	0.75	0.39	5.31	2.91	2.44	0.12	0.08
VG 95343 T08 D004A	311-1	2.19	1.06	1.00	0.49	7.56	4.06	3.50	0.18	0.12

MATERIALS AVAILABLE

Reference	Specification	Description
J	* MIL-I-81765/TYPE II	Flexible modified polyolefin
B7	* MIL-I-81765/TYPE I	Semi-rigid flame retarded polyolefin
G	* VG 95343 PART 6	Fluid resistant elastomer
H	NAVSEA 5617649	Flexible limited fire hazard material

ADHESIVE COATING OPTIONS

Reference	Description
WM250	General purpose hot melt +80°C
W8	High performance hot melt +105°C
W24	1 Part Epoxy 200°C

* Standard products and materials.

300 SERIES

3-WAY OUTLET SHAPES IN LINE



This style provides cable sealing strain relief and mechanical protection. Covers a wide range of cable diameters. Ideal for power and signal applications.

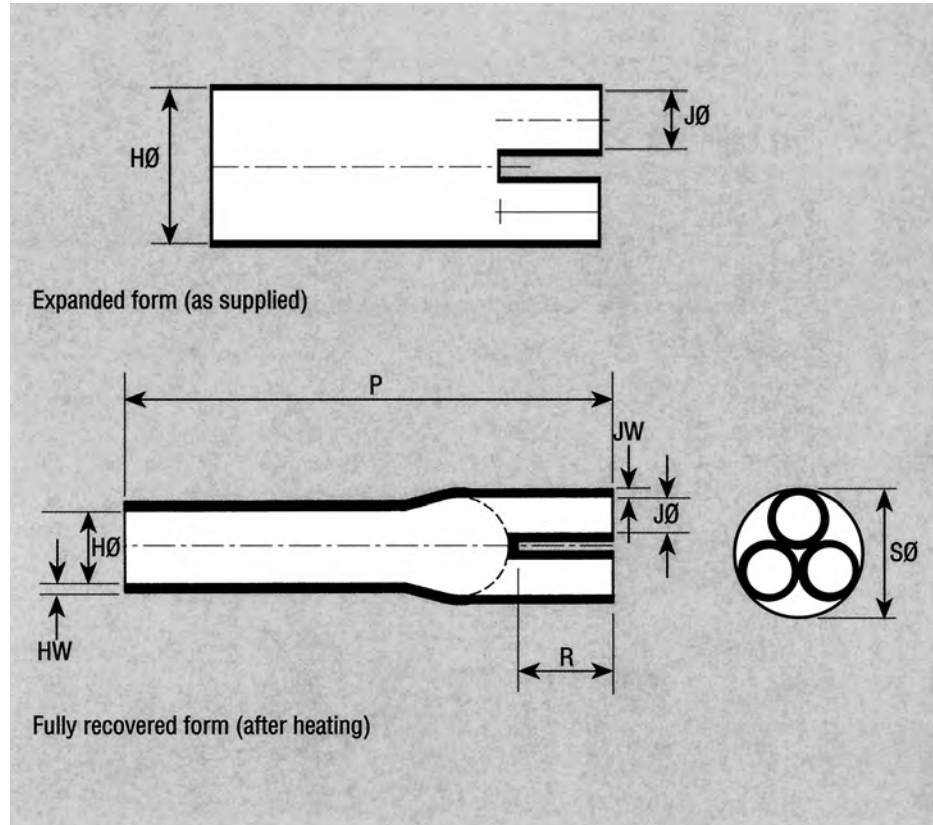

Dimensions apply to all materials unless otherwise indicated and are in inches.

NAVSEA REFERENCE	Hellermann Part No.	Expanded (Min)		Recovered (Max)		Recovered dimensions fully shrunk				
		H	J	H	J	S (Nom)	P ±10%	R ±10%	HW ±20%	W ±20%
IA62-5	* 318-2	0.98	0.35	0.36	0.12	0.63	3.01	0.79	0.10	0.10
IA62-7	* 339-2	1.50	0.65	0.50	0.16	1.02	4.47	2.46	0.11	0.11
IA62-6	* 319-2	1.22	0.59	0.69	0.18	0.91	3.68	1.12	0.11	0.11
—	* 320-1	2.20	1.20	0.89	0.35	1.46	7.09	1.73	0.12	0.12
IA62-8	* 328-2	1.70	0.82	0.90	0.30	1.42	3.90	1.34	0.15	0.15
—	355-1	3.94	1.57	1.10	0.51	N/A	8.27	1.97	0.14	0.10
—	342-1		1.57	1.38	0.69	2.17	9.06	1.77	0.16	0.14
IA62-9	* 330-2	2.40	1.25	1.40	0.50	1.85	5.69	1.79	0.15	0.15
IA62-10	* 340-2	3.20	1.40	2.00	0.75	2.56	5.69	1.79	0.18	0.18
IA62-11	* 341-2	4.92	2.00	2.32	1.00	2.95	11.14	2.80	0.15	0.15
—	323-1	4.72	2.36	2.36	0.98	3.35	11.81	3.54	0.16	0.12

MATERIALS AVAILABLE

Reference	Specification	Description
J	MIL-I-81765/TYPE II	Flexible modified polyolefin
B7	* MIL-I-81765/TYPE I	Semi-rigid flame retarded polyolefin
G	VG 95343 PART 6	Fluid resistant elastomer
H	NAVSEA 5617649	Flexible limited fire hazard material
B8		Semi-rigid polyolefin

ADHESIVE COATING OPTIONS

Reference	Description
W1	Band lined WM250

*Standard products and material.

For ordering procedure – refer to page 5

400 SERIES

4-WAY OUTLET

SHAPES-VG STYLE

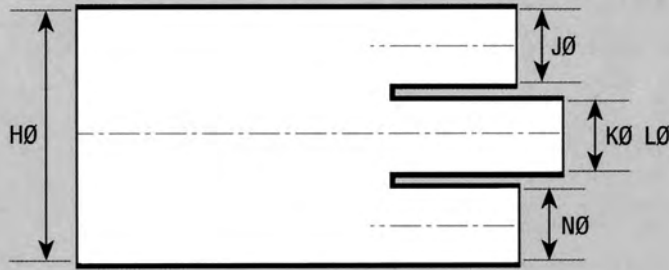
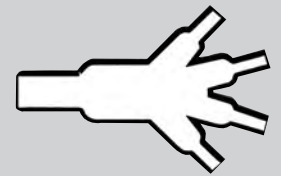

Expanded form (as supplied)

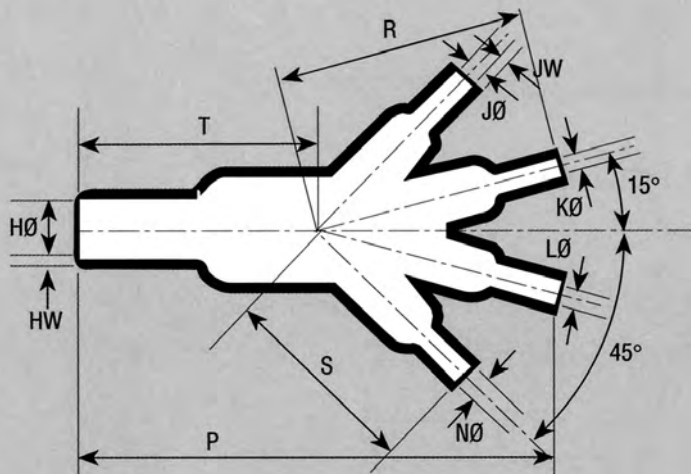

Fully recovered form (after heating)

This style provides cable sealing strain relief and mechanical protection.

Dimensions apply to all materials unless otherwise indicated and are in inches.

VG Part No.	Hellermann Part No.	Expanded (Min)		Recovered (Max)		Recovered dimensions fully shrunk					
		H	J,K,L,N	H	J,K,L,N	P ±15%	T ±10%	S ±10%	R ±10%	HW ±30%	JW ±30%
VG 95343 T08E 002A	* 411-1	0.75	0.37	0.39	0.22	2.80	1.42	1.26	1.42	0.08	0.04
VG 95343 T08E 004A	403-1	1.06	0.51	0.51	0.28	4.02	1.93	1.77	2.05	0.10	0.06
VG 95343 T08E 005A	* 413-1	1.52	0.75	0.75	0.39	5.91	2.95	2.56	2.83	0.07	0.04

MATERIALS AVAILABLE

Reference	Specification	Description
J	* MIL-I-81765/TYPE II	Flexible modified polyolefin
B7	* MIL-I-81765/TYPE I	Semi-rigid flame retarded polyolefin
G	* VG 95343 PART 6	Fluid resistant elastomer
H	NAVSEA 5617649	Flexible limited fire hazard material

ADHESIVE COATING OPTIONS

Reference	Description
WM250	General purpose hot melt +80°C
W8	High performance hot melt +105°C
W24	1 Part Epoxy 200°C

* Standard products and materials.

For ordering procedure – refer to page 5

400 SERIES

4-WAY OUTLET SHAPES IN LINE



This style provides cable sealing strain relief and mechanical protection. Ideal for power and signal applications.

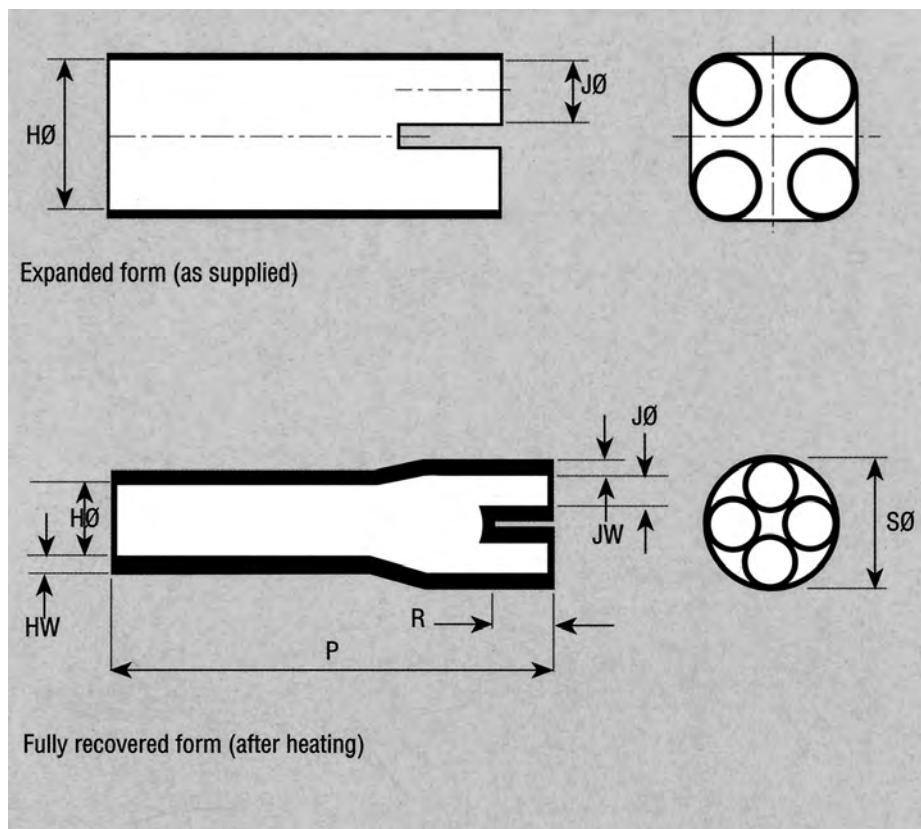

Dimensions apply to all materials unless otherwise indicated and are in inches.

NAVSEA REFERENCE	Part No	Expanded (Min)		Recovered (Max)		Recovered dimensions fully shrunk				
		H	J	H	J	P ±10%	R ±10%	S (nom)	HW ±20%	JW ±20%
—	442-1	1.10	0.35	0.35	0.07	3.07	0.67	0.79	0.11	0.08
IA62-12	* 434-2	0.98	0.28	0.43	0.11	3.07	0.85	0.71	0.06	0.06
—	443-1	1.38	0.59	0.47	0.12	4.72	1.02	0.87	0.12	0.10
—	408-2	1.38	0.59	0.47	0.12	3.74	0.94	0.87	0.10	0.08
IA62-13	* 435-2	1.26	0.51	0.80	0.19	3.68	1.12	1.06	0.11	0.11
—	418-4	2.36	1.18	0.90	0.25	7.95	1.50	1.50	0.16	0.13
—	436-2	1.77	0.79	0.98	0.28	3.90	1.34	1.54	0.18	0.18
IA62-15	* 437-2	2.36	1.00	1.00	0.35	9.45	1.89	1.69	0.18	0.18
IA62-16	* 438-2	2.64	1.20	1.40	0.53	5.57	1.67	2.13	0.18	0.18
—	444-1	3.10	1.50	1.40	0.49	9.45	2.17	2.00	0.13	0.13
IA62-17	* 439-2	5.25	1.35	3.00	0.55	10.02	3.35	3.26	0.13	0.16

MATERIALS AVAILABLE

Reference	Specification	Description
J	MIL-I-81765/TYPE II	Flexible modified polyolefin
B7	* MIL-I-81765/TYPE I	Semi-rigid flame retarded polyolefin
G	VG 95343 PART 6	Fluid resistant elastomer
H	NAVSEA 5617649	Flexible limited fire hazard material
B8		Semi-rigid polyolefin

ADHESIVE COATING OPTIONS

Reference	Description
W1	Band lined WM250

* Standard products and material.

For ordering procedure – refer to page 5

500 SERIES

5-WAY OUTLET
SHAPE IN LINE



This style provides cable sealing, strain relief and mechanical protection. Ideal for power and signal applications.

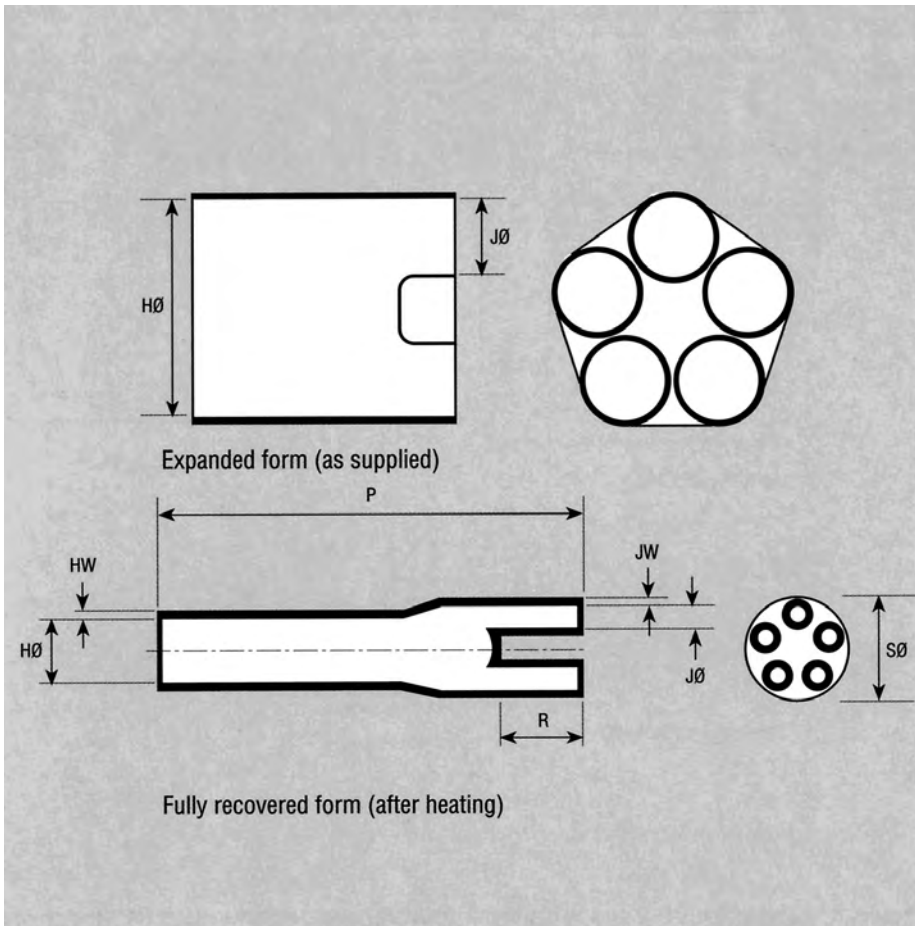

Dimensions apply to all materials unless otherwise indicated and are in inches.

Hellermann Part No.	Expanded (Min)				Recovered (Max)			Recovered dimensions fully shrunk			
	H	H -H Matl	J	J -H Matl	H	J	S (Nom)	P ±10%	R ±10%	HW ±20%	JW ±20%
508-1	2.36	2.36	1.18	0.89	0.96	0.30	1.89	7.09	1.18	0.14	0.12

MATERIALS AVAILABLE

Reference	Specification	Description
J	* MIL-I-81765/TYPE II	Flexible modified polyolefin
B7	* MIL-I-81765/TYPE I	Semi-rigid flame retarded polyolefin
G	VG 95343 PART 6	Fluid resistant elastomer
H	NAVSEA 5617649	Flexible limited fire hazard material
B8		Semi-rigid polyolefin

ADHESIVE COATING OPTIONS

Reference	Description
W1	Band lined WM250

*Standard materials.

600 SERIES

6-WAY OUTLET

SHAPES IN LINE



This style provides cable sealing strain relief and mechanical protection. Ideal for power and signal cables.

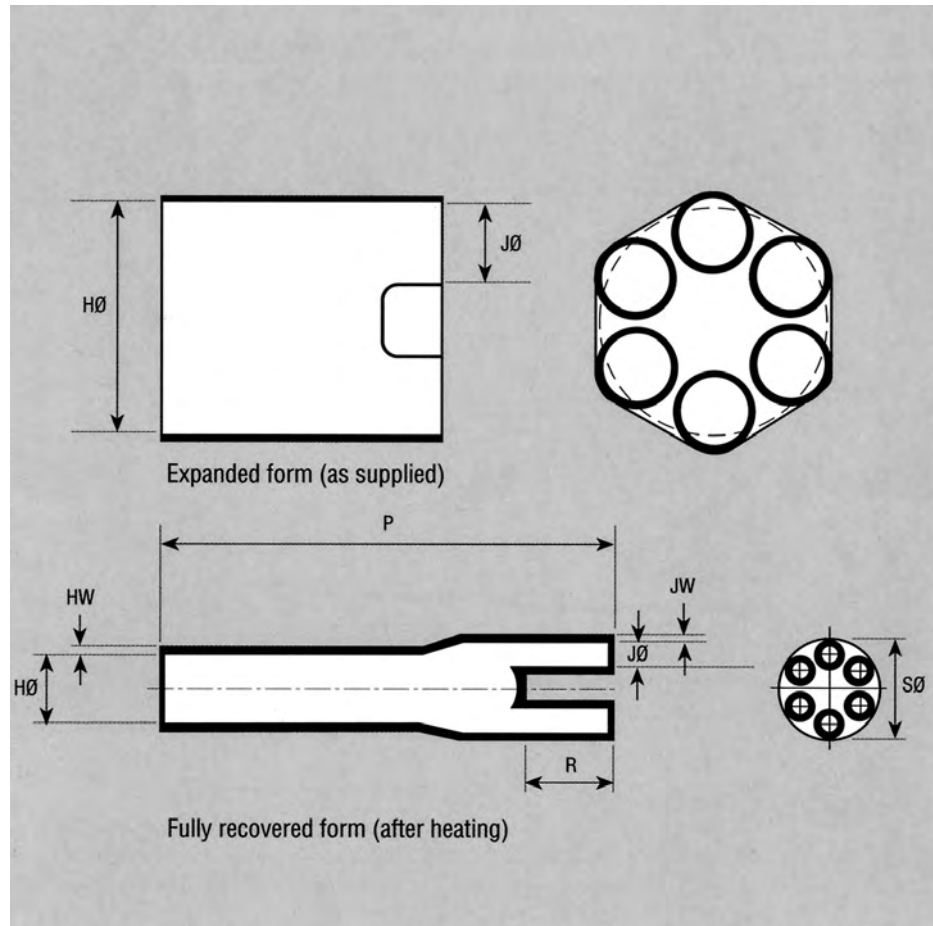

Dimensions apply to all materials unless otherwise indicated and are in inches.

NAVSEA REFERENCE	Hellermann Part No.	Expanded (Min)		Recovered (Max)		Recovered dimensions fully shrunk				
		H	J	H	J	S (nom)	P ±10%	R ±10%	HW ±20%	JW ±20%
—	609-1	1.18	0.32	0.63	0.16	0.98	2.95	0.78	0.10	0.06
IA62-18	* 608-1	2.39	0.82	1.45	0.35	1.97	6.00	2.00	0.10	0.10

MATERIALS AVAILABLE		
Reference	Specification	Description
J	* MIL-I-81765/TYPE II	Flexible modified polyolefin
B7	* MIL-I-81765/TYPE I	Semi-rigid flame retarded polyolefin
G	VG 95343 PART 6	Fluid resistant elastomer
H	NAVSEA 5617649	Flexible limited fire hazard material
B8		Semi-rigid polyolefin

ADHESIVE COATING OPTIONS	
Reference	Description
W1	Band lined WM250

* Standard products and material.

For ordering procedure – refer to page 5

1100 SERIES

RIGHT-ANGLE SHAPES WITH RIB-VG STYLE

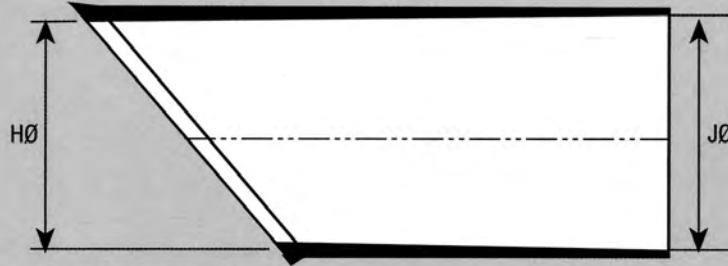

Expanded form (as supplied)

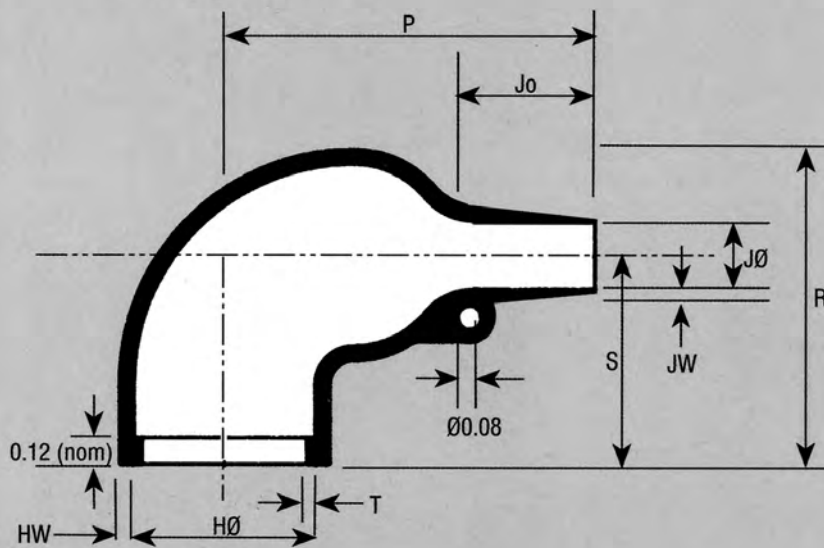

Fully recovered form (after heating)

This style provides strain relief for harness systems when used in conjunction with a circular grooved adaptor.

For VG shapes according to T07 add 'P' after Hellermann part number.

Dimensions apply to all materials unless otherwise indicated and are in inches.

Dimensions in inches		Expanded (Min)		Recovered (Max)		Recovered dimensions fully shrunk						
VG Part No.	Hellermann Part No.	H	J	H	J	P ±10%	R ±10%	S ±10%	Jo ±10%	HW ±20%	JW ±20%	T ±10%
VG 95343 T06 E001A	* 1152-4	0.94	0.94	0.41	0.24	1.02	0.98	0.75	0.39	0.05	0.02	0.04
VG 95343 T06 E002A	* 1154-4	1.18	1.18	0.61	0.24	1.26	1.06	0.79	0.47	0.06	0.03	0.04
VG 95343 T06 E003A	* 1155-4	1.22	1.22	0.71	0.28	1.57	1.22	0.83	0.59	0.07	0.04	0.04
VG 95343 T06 E004A	* 1156-4	1.42	1.42	0.89	0.33	1.81	1.50	1.02	0.59	0.07	0.04	0.04
VG 95343 T06 E005A	* 1157-4	1.69	1.69	1.12	0.39	2.17	1.77	1.18	0.63	0.08	0.04	0.07
VG 95343 T06 E006A	* 1158-4	2.36	2.36	1.38	0.63	3.15	2.13	1.38	1.18	0.13	0.06	0.07
VG 95343 T06 E007A	* 1159-4	2.60	2.60	1.77	0.67	4.25	2.68	1.65	2.01	0.15	0.08	0.08
VG 95343 T06 E008A	1160-4	3.23	3.23	2.40	0.98	4.65	3.31	2.05	1.54	0.16	0.16	0.08

MATERIALS AVAILABLE

Reference	Specification	Description
J	* MIL-I-81765/TYPE II	Flexible modified polyolefin
B7	* MIL-I-81765/TYPE I	Semi-rigid flame retarded polyolefin
G	* VG 95343 PART 6	Fluid resistant elastomer
H	* NAVSEA 5617649	Flexible limited fire hazard material

ADHESIVE COATING OPTIONS

Reference	Description
WM250	General purpose hot melt +80°C
W8	High performance hot melt +105°C
W24	1 Part Epoxy 200°C

* Standard products and materials.

For ordering procedure – refer to page 5

1100 SERIES

RIGHT ANGLE SHAPES

THICK WALL WITHOUT RIB-VG STYLE

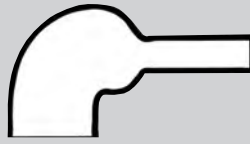

This style provides connector cable strain relief. Can be installed directly onto connector rear thread.

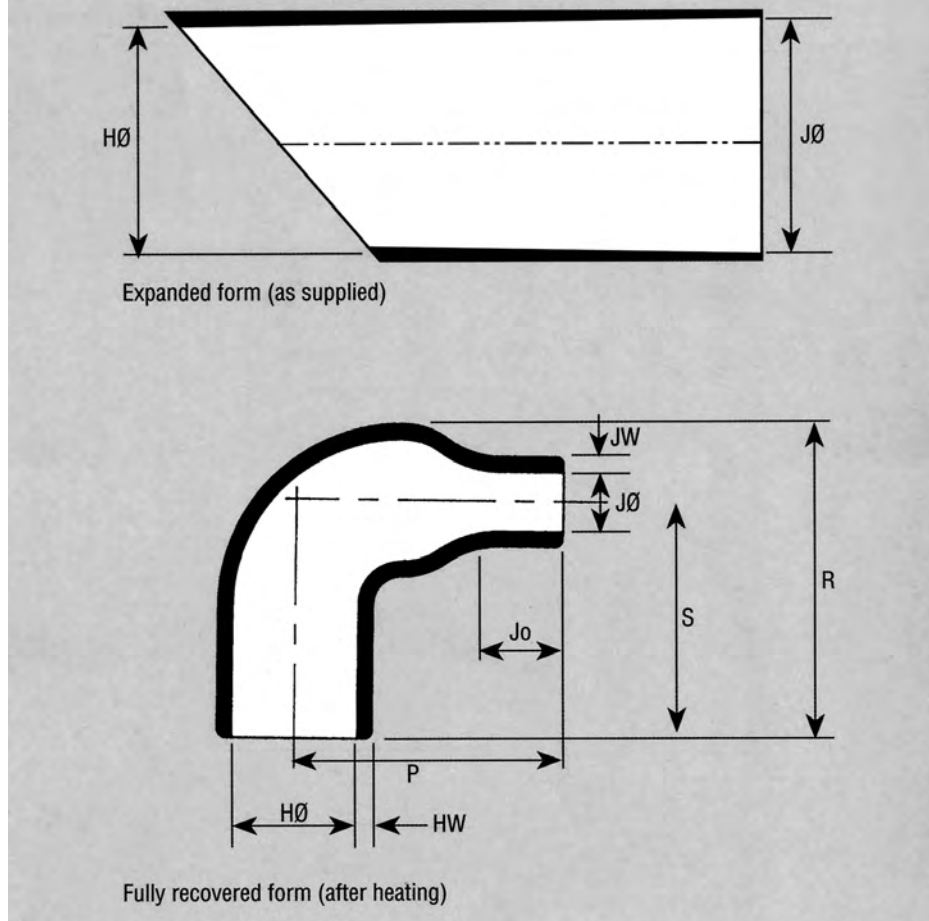

Dimensions apply to all materials unless otherwise indicated and are in inches.

VG Part No.	Hellermann Part No.	Expanded (Min)		Recovered (Max)		Recovered dimensions fully shrunk					
		H	J	H	J	P ±10%	R ±10%	S ±10%	Jo ±10%	HW ±30%	JW ±30%
VG 95343 T06 J002A	1112-1	0.53	0.26	0.41	0.14	1.26	0.91	0.67	0.30	0.06	0.04
VG 95343 T06 J003A	1113-1	0.75	0.31	0.57	0.18	1.54	1.02	0.75	0.31	0.10	0.04
VG 95343 T06 J004A	1114-1	0.93	0.45	0.71	0.22	2.01	1.30	0.87	0.37	0.12	0.04
VG 95343 T06 J008A	1118-1	2.34	1.73	1.77	0.83	5.24	2.87	1.77	1.57	0.28	0.20

MATERIALS AVAILABLE

Reference	Specification	Description
J	MIL-I-81765/TYPE II	Flexible modified polyolefin
B7	MIL-I-81765/TYPE I	Semi-rigid flame retarded polyolefin
G	VG 95343 PART 6	Fluid resistant elastomer
H	NAVSEA 5617649	Flexible limited fire hazard material

ADHESIVE COATING OPTIONS

Reference	Description
WM250	General purpose hot melt +80°C
W8	High performance hot melt +105°C
W24	1 Part Epoxy 200°C

For ordering procedure – refer to page 5

1100 SERIES

RIGHT-ANGLE

SHAPES WITH RIB- MIL STYLE

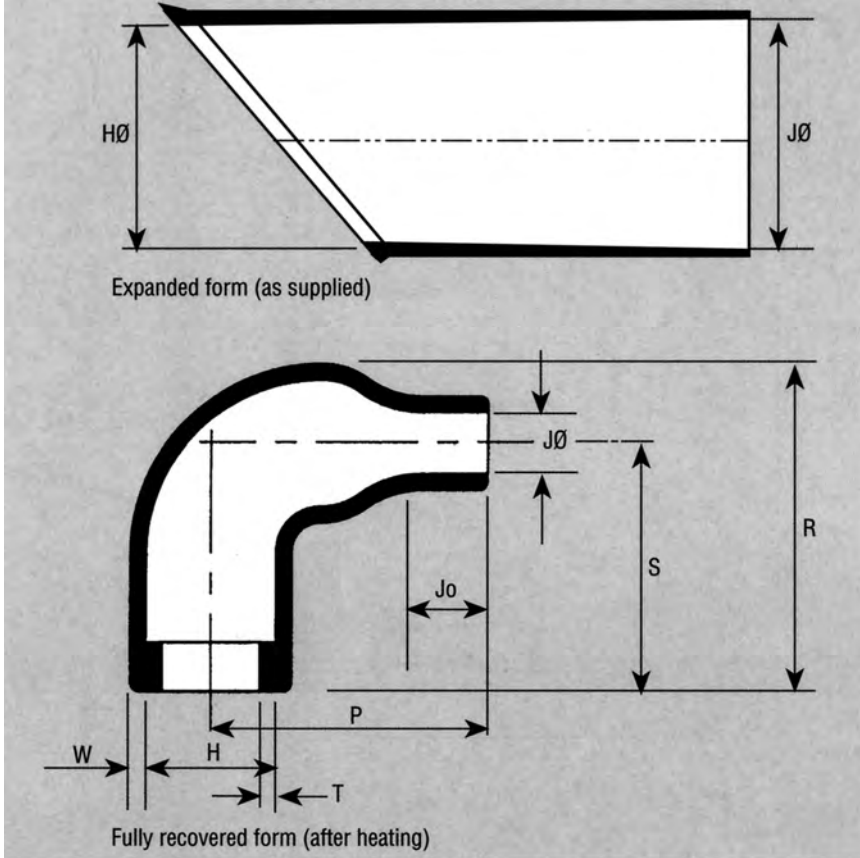
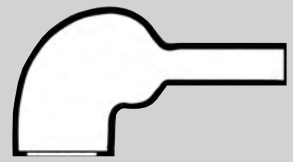

This style provides strain relief for harness systems when used in conjunction with a circular grooved adaptor.

Dimensions apply to all materials unless otherwise indicated and are in inches.

MIL Spec No.	Hellermann Part No.	Expanded (Min)		Recovered (Max)		Recovered dimensions fully shrunk					
		H	J	H	J	P ±10%	R ±10%	S ±10%	Jo ±10%	W ±20%	T ±20%
	1181-4	0.47	0.24	0.38	0.08	0.75	0.51	0.41	0.24	0.04	0.02
	* 1108-4	0.65	0.65	0.31	0.15	0.68	0.79	0.60	0.16	0.04	0.04
MS3117-11	* 1106-4	0.92	0.92	0.41	0.22	0.80	0.90	0.60	0.23	0.05	0.04
MS3117-12	* 1107-4	1.12	1.12	0.56	0.25	1.17	1.12	0.84	0.28	0.06	0.04
MS3117-13	* 1104-4	1.22	1.22	0.70	0.28	1.40	1.20	0.81	0.34	0.07	0.04
MS3117-14	* 1103-4	1.42	1.42	0.88	0.33	1.70	1.40	0.90	0.50	0.07	0.04
MS3117-15	* 1101-4	1.68	1.68	1.10	0.38	2.10	1.70	1.10	0.62	0.08	0.07
MS3117-16	1105-4	2.04	2.04	1.38	0.62	3.10	2.10	1.30	1.20	0.13	0.07
MS3117-17	1109-4	2.60	2.60	1.75	0.80	3.84	2.60	1.64	1.60	0.15	0.08

MATERIALS AVAILABLE		
Reference	Specification	Description
J	* MIL-I-81765/TYPE II	Flexible modified polyolefin
B7	* MIL-I-81765/TYPE I	Semi-rigid flame retarded polyolefin
G	VG 95343 PART 6	Fluid resistant elastomer
H	NAVSEA 5617649	Flexible limited fire hazard material

ADHESIVE COATING OPTIONS	
Reference	Description
WM250	General purpose hot melt +80°C
W8	High performance hot melt +105°C
W24	1 Part Epoxy 200°C

* Standard products and materials.

For ordering procedure – refer to page 5

1100 SERIES

RIGHT-ANGLE SHAPES WITHOUT RIB

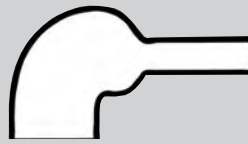

This style provides connector cable strain relief. Can be installed directly onto connector rear thread.

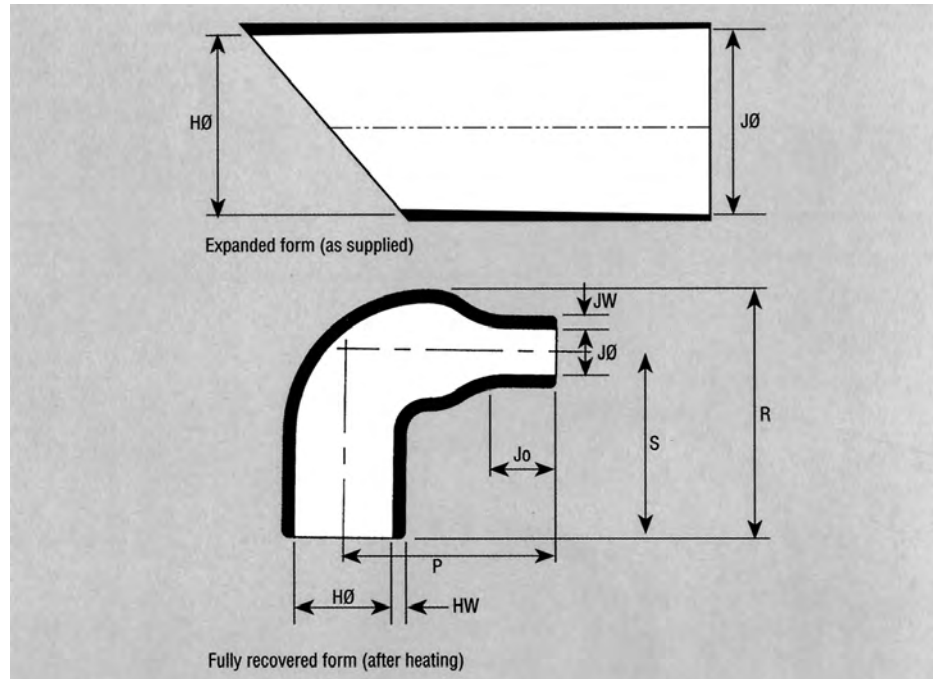

Dimensions apply to all materials unless otherwise indicated and are in inches

Hellermann Part No.	Expanded (Min)		Recovered (Max)		Recovered dimensions fully shrunk				
	H	J	H	J	P ±10%	R ±10%	S ±10%	Jo ±10%	W ±10%
* 1108-1	0.65	0.65	0.31	0.15	0.68	0.79	0.60	0.16	0.04
* 1108-2	0.42	0.33	0.31	0.15	0.68	0.79	0.60	0.16	0.04
1106-1	0.93	0.93	0.41	0.22	0.80	0.90	0.60	0.23	0.05
1106-2	0.54	0.46	0.41	0.22	0.80	0.90	0.60	0.23	0.05
* 1107-1	1.12	1.12	0.56	0.25	0.84	0.84	0.73	0.28	0.06
* 1107-2	0.76	0.56	0.56	0.25	0.84	0.84	0.73	0.28	0.06
* 1104-1	0.95	0.62	0.70	0.28	1.40	1.20	0.81	0.34	0.07
* 1104-2	1.25	1.25	0.70	0.28	1.40	1.20	0.81	0.34	0.07
* 1103-1	1.50	1.50	0.88	0.33	1.70	1.40	0.90	0.50	0.07
* 1103-2	1.20	0.75	0.88	0.33	1.70	1.40	0.90	0.50	0.07
* 1101-1	1.70	1.70	1.10	0.38	2.18	1.70	1.10	0.62	0.08
* 1101-2	1.50	0.90	1.10	0.38	2.18	1.70	1.10	0.62	0.08
1105-1	2.06	2.06	1.38	0.62	3.10	2.10	1.30	1.20	0.13
1105-2	1.85	1.40	1.38	0.62	3.10	2.10	1.30	1.20	0.13
1109-1	2.60	2.60	1.75	0.80	3.84	2.60	1.64	1.60	0.15
1109-2	2.34	1.72	1.75	0.80	3.84	2.60	1.64	1.60	0.15
1109-3	3.00	3.00	1.75	0.80	3.84	2.60	1.64	1.60	0.15

MATERIALS AVAILABLE

Reference	Specification	Description
J	* MIL-I-81765/TYPE II	Flexible modified polyolefin
B7	* MIL-I-81765/TYPE I	Semi-rigid flame retarded polyolefin
G	VG 95343 PART 6	Fluid resistant elastomer
H	NAVSEA 5617649	Flexible limited fire hazard material

ADHESIVE COATING OPTIONS

Reference	Description
WM250	General purpose hot melt +80°C
W8	High performance hot melt +105°C
W24	1 Part Epoxy 200°C

* Standard products and materials.

For ordering procedure – refer to page 5

1100 SERIES

RIGHT-ANGLE
LOW PROFILE SHAPES
WITH RIB-VG/MIL STYLE

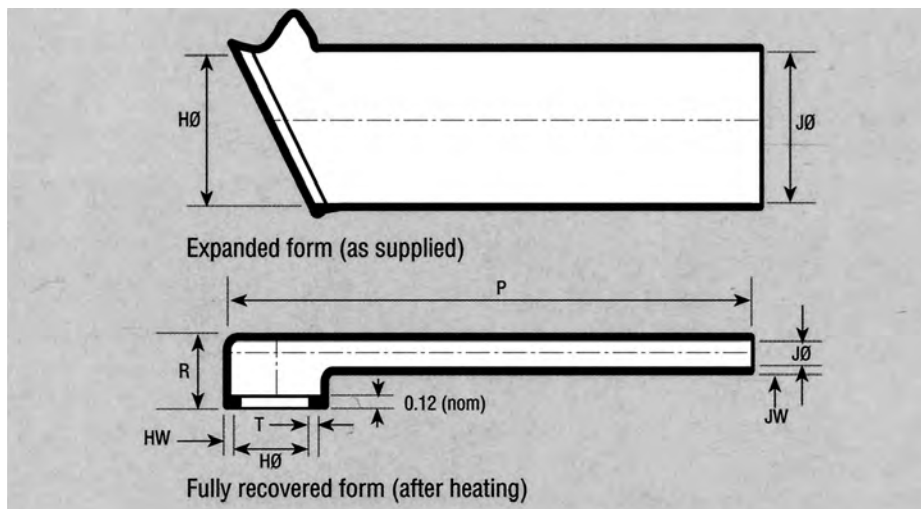
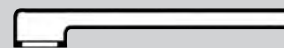

This style is typically used on airborne harnesses to achieve low profile, compact strain relief and mechanical protection.

VG shapes according to T07 add 'P' after Hellermann Part Number.

Dimensions apply to all materials unless otherwise indicated and are in inches.

VG Part No.	Hellermann Part No.	Expanded (Min)		Recovered (Max)		Recovered dimensions fully shrunk				
		H	J	H	J	P ±10%	R ±10%	T ±10%	HW ±20%	JW ±30%
VG 95343 T06 F001	1121-1	0.87	0.87	0.47	0.26	2.76	0.75	0.04	0.06	0.04
VG 95343 T06 F002	* 1122-1	1.00	1.00	0.59	0.30	3.11	0.79	0.04	0.06	0.04
VG 95343 T06 F003	* 1123-1	1.14	1.14	0.75	0.33	3.50	0.83	0.04	0.07	0.04
VG 95343 T06 F004	* 1124-1	1.34	1.34	0.91	0.39	4.02	0.87	0.04	0.07	0.04
VG 95343 T06 F005	* 1125-1	1.46	1.46	1.18	0.43	4.25	0.94	0.07	0.08	0.04
VG 95343 T06 F006	* 1126-1	1.71	1.71	1.34	0.47	4.76	1.06	0.07	0.08	0.04
VG 95343 T06 F007	1127-1	1.97	1.97	1.63	0.57	5.20	1.18	0.07	0.09	0.06
VG 95343 T06 F008	1128-1	2.46	2.46	1.85	0.71	5.24	1.30	0.08	0.10	0.06
VG 95343 T06 F009	1129-1	2.72	2.72	2.36	0.79	5.39	1.40	0.08	0.10	0.06
VG 95343 T06 F010	1141-1	3.23	3.23	2.64	0.91	5.51	1.77	0.08	0.10	0.06
MIL Spec. No.										
MS 3117-01-	1121-4	0.88	0.88	0.41	0.23	4.14	0.73	0.04	0.06	0.04
MS 3117-02-	* 1122-4	1.01	1.01	0.54	0.26	4.88	0.78	0.04	0.06	0.04
MS 3117-03-	* 1123-4	1.16	1.16	0.68	0.30	5.76	0.82	0.04	0.07	0.04
MS 3117-04-	* 1124-4	1.34	1.34	0.82	0.35	6.78	0.86	0.04	0.07	0.04
MS 3117-05-	* 1125-4	1.47	1.47	1.06	0.37	7.29	0.96	0.07	0.08	0.04
	1125-2	1.62	1.62	1.06	0.37	3.23	0.96	0.07	0.08	0.04
MS 3117-06	* 1126-4	1.72	1.72	1.22	0.44	8.41	1.08	0.07	0.08	0.04
MS 3117-07	1127-4	1.97	1.97	1.48	0.51	8.84	1.16	0.07	0.09	0.06
	1127-3	1.97	1.97	1.48	0.51	2.56	1.16	0.07	0.09	0.06
MS 3117-08-	1128-4	2.47	2.47	1.69	0.69	8.95	1.30	0.08	0.10	0.06
MS 3117-09-	1129-4	2.73	2.73	2.15	0.70	9.19	1.38	0.08	0.10	0.06

MATERIALS AVAILABLE

Reference	Specification	Description
J	* MIL-I-81765/TYPE II	Flexible modified polyolefin
B7	* MIL-I-81765/TYPE I	Semi-rigid flame retarded polyolefin
G	* VG 95343 PART 6	Fluid resistant elastomer

ADHESIVE COATING OPTIONS

Reference	Description
WM250	General purpose hot melt +80°C
W8	High performance hot melt +105°C
W24	1 Part Epoxy 200°C

* Standard products and materials.

For ordering procedure – refer to page 5

1100 SERIES

RIGHT-ANGLE SHAPES
LOW PROFILE HIGH RATIO
WITH RIB-VG STYLE



This style provides connector cable strain relief. Used in applications of partially loaded connectors with small cable diameters.

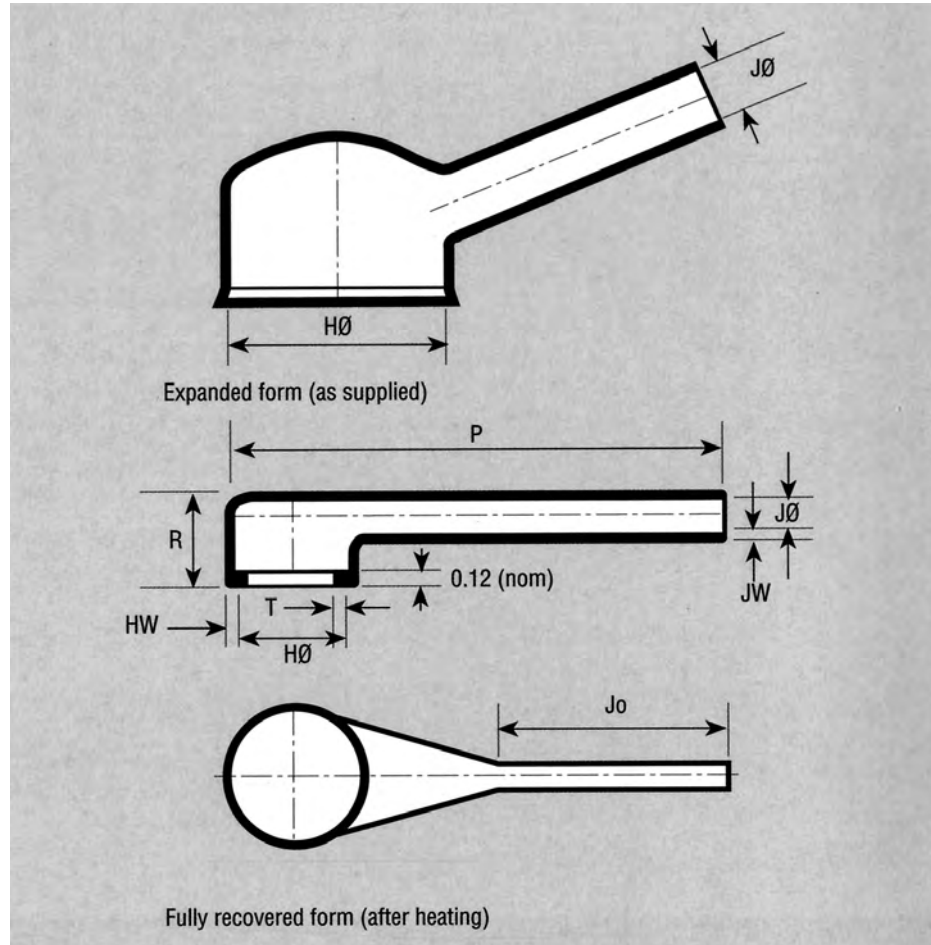

Dimensions apply to all materials unless otherwise indicated and are in inches.

VG Part No.	Hellermann Part No.	Expanded (Min)		Recovered (Max)		Recovered dimensions fully shrunk					
		H	J	H	J	P ±10%	R ±10%	Jo ±10%	T ±10%	HW ±20%	JW ±20%
VG 95343 T06 F011A	1133-1	0.75	0.24	0.51	0.08	1.77	0.63	0.87	0.04	0.06	0.04
	1133-2	0.76	0.25	0.51	0.08	1.18	0.64	0.29	0.12	0.06	0.04
VG 95343 T06 F012A	1134-1	1.02	0.30	0.75	0.10	2.64	0.71	1.14	0.04	0.07	0.04
VG 95343 T06 F013A	1135-1	1.34	0.37	1.02	0.12	3.19	0.75	1.40	0.04	0.07	0.04
	1135-2	1.35	0.38	1.02	0.12	2.17	0.74	0.36	0.12	0.07	0.04
VG 95343 T06 F014A	1136-1	1.71	0.45	1.34	0.14	4.57	0.83	1.85	0.07	0.07	0.04

MATERIALS AVAILABLE

Reference	Specification	Description
J	* MIL-I-81765/TYPE II	Flexible modified polyolefin
B7	* MIL-I-81765/TYPE I	Semi-rigid flame retarded polyolefin
G	* VG 95343 PART 6	Fluid resistant elastomer
H	NAVSEA 5617649	Flexible limited fire hazard material

ADHESIVE COATING OPTIONS

Reference	Description
WM250	General purpose hot melt +80°C
W8	High performance hot melt +105°C
W24	1 Part Epoxy 200°C

* Standard material.

For ordering procedure – refer to page 5

1200 SERIES

T SHAPES
-VG STYLE

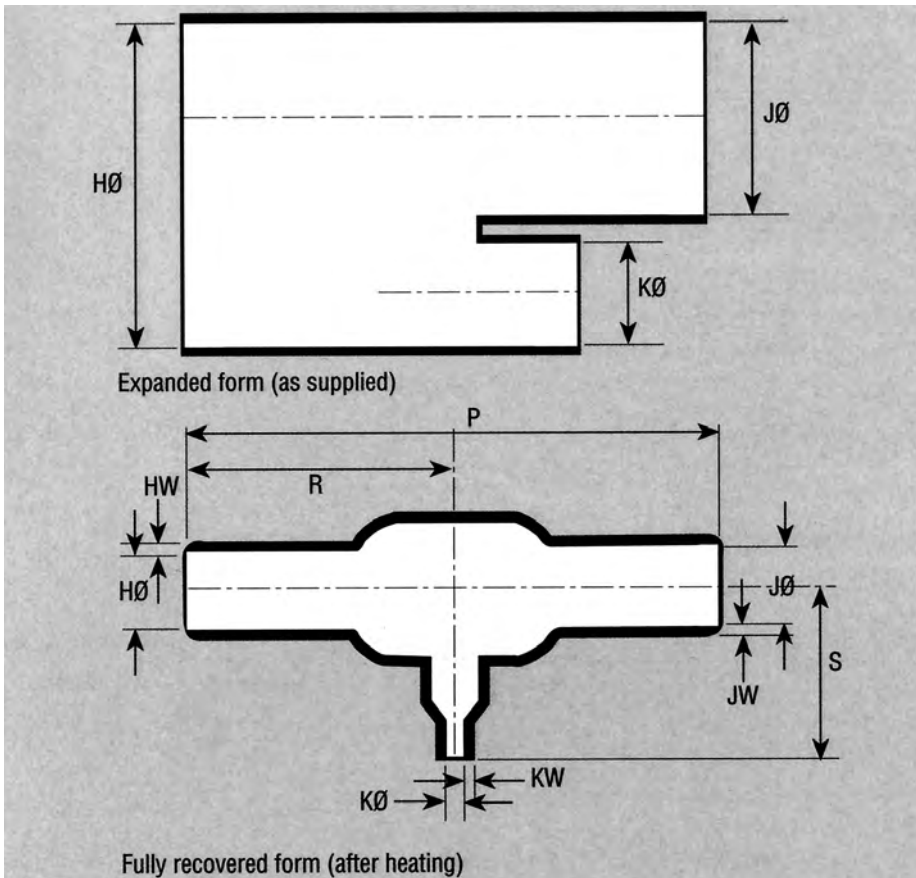
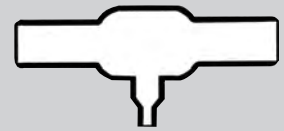

This style provides strain relief, sealing and mechanical protection on cable harnesses.

VG shapes according to T09 add 'P' after Hellermann part number

Dimensions apply to all materials unless otherwise indicated and are in inches.

VG Part No.	Hellermann Part No.	Expanded (Min)			Recovered (Max)			Recovered dimensions fully shrunk				
		H	J	K	H	J	K	P ±10%	R ±10%	S ±10%	KW +20%	HW, JW +20%
VG 95343 T08 A009A	* 1206-1	0.26	0.26	0.26	0.12	0.12	0.12	1.17	0.58	0.58	0.04	0.04
VG 95343 T08 A001A	* 1203-1	0.52	0.52	0.26	0.24	0.12	0.12	2.05	1.02	0.76	0.04	0.06
VG 95343 T08 A010A	* 1202-1	0.52	0.52	0.52	0.24	0.24	0.24	2.31	1.15	1.15	0.06	0.06
—	* 1205-1	0.70	0.67	0.30	0.35	0.35	0.15	2.00	1.00	1.00	0.04	0.06
VG 95343 T08 A007A	1201-1	0.70	0.70	0.40	0.35	0.35	0.20	1.87	0.93	0.93	0.04	0.06
VG 95343 T08 A002A	* 1209-1	1.06	1.06	0.52	0.49	0.49	0.24	4.25	2.13	2.13	0.06	0.10
VG 95343 T08 A011A	* 1207-1	1.06	1.06	1.06	0.49	0.49	0.49	4.73	2.20	2.20	0.10	0.10
—	1230-1	0.78	0.78	0.78	0.40	0.40	0.40	3.54	1.77	1.77	0.08	0.08
—	1221-1	0.98	0.98	0.98	0.39	0.39	0.39	4.21	2.10	2.10	0.08	0.08

MATERIALS AVAILABLE

Reference	Specification	Description
J	* MIL-I-81765/TYPE II	Flexible modified polyolefin
B7	* MIL-I-81765/TYPE I	Semi-rigid flame retarded polyolefin
G	* VG 95343 PART 6	Fluid resistant elastomer
H	NAVSEA 5617649	Flexible limited fire hazard material

ADHESIVE COATING OPTIONS

Reference	Description
WM250	General purpose hot melt +80°C
W8	High performance hot melt +105°C
W24	1 Part Epoxy 200°C

* Standard products and material.

1200 SERIES

OFF-SET T SHAPES

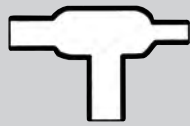

This style provides strain relief, sealing and mechanical protection on cable harness.

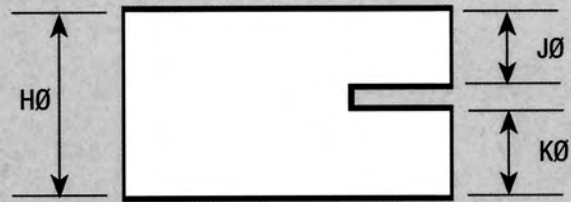

Expanded form (as supplied)

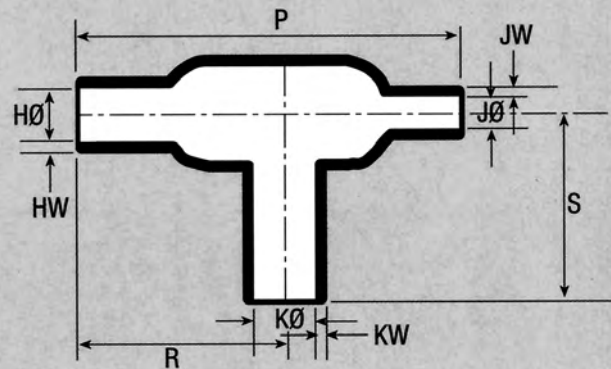

Fully recovered form (after heating)

Dimensions apply to all materials unless otherwise indicated and are in inches.

Hellermann Part No.	Expanded (Min)			Recovered (Max)			Recovered dimensions fully shrunk					
	H	J	K	H	J	K	P ±10%	R ±10%	S ±10%	HW ±20%	JW ±20%	KW ±20%
1217-1	0.39	0.24	0.24	0.10	0.09	0.10	2.24	0.75	0.93	0.04	0.04	0.04
1222-1	1.22	0.71	0.98	0.60	0.35	0.59	3.62	2.05	1.77	0.09	0.09	0.09
1223-1	1.16	0.38	1.16	0.64	0.21	0.64	3.67	2.23	2.23	0.10	0.07	0.07

MATERIALS AVAILABLE

Reference	Specification	Description
J	MIL-I-81765/TYPE II	Flexible modified polyolefin
B7	MIL-I-81765/TYPE I	Semi-rigid flame retarded polyolefin
G	VG 95343 PART 6	Fluid resistant elastomer
H	NAVSEA 5617649	Flexible limited fire hazard material

ADHESIVE COATING OPTIONS

Reference	Description
WM250	General purpose hot melt +80°C
W8	High performance hot melt +105°C
W24	1 Part Epoxy 200°C

For ordering procedure – refer to page 5

1200 SERIES

OFF-SET
T SHAPES-VG STYLE

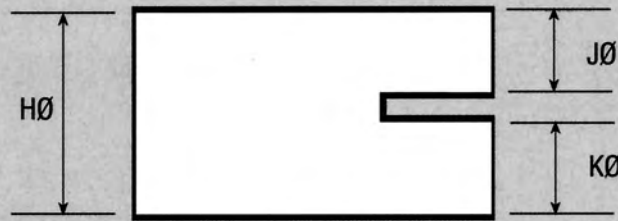
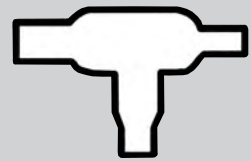

Expanded form (as supplied)

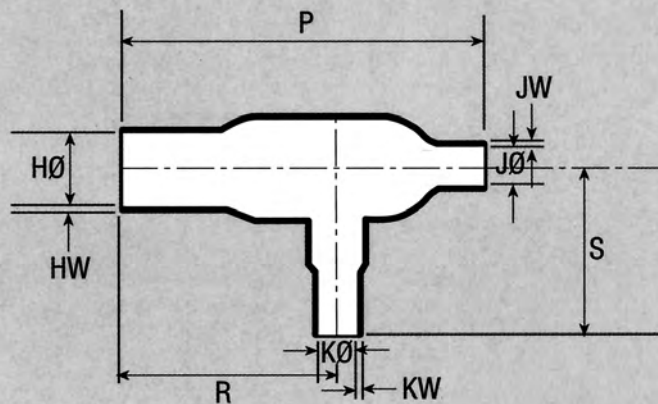

Fully recovered form (after heating)

This style provides strain relief, sealing and mechanical protection on cable harnesses.

Dimensions apply to all materials unless otherwise indicated and are in inches.

VG Part No.	Hellermann Part No.	Expanded (Min)			Recovered (Max)			Recovered dimensions fully shrunk					
		H	J	K	H	J	K	P ±10%	R ±10%	S ±10%	HW ±20%	JW ±20%	KW ±20%
VG 95343 T08 A016A	* 1204-1	0.51	0.26	0.26	0.30	0.16	0.16	2.20	1.30	0.76	0.06	0.04	0.04
VG 95343 T08 A017A	* 1216-1	1.30	0.65	0.65	0.51	0.26	0.26	3.82	2.13	1.52	0.10	0.06	0.06
—	* 1226-1	1.20	0.70	0.70	0.60	0.35	0.35	3.20	1.87	1.50	0.09	0.05	0.05

MATERIALS AVAILABLE

Reference	Specification	Description
J	* MIL-I-81765/TYPE II	Flexible modified polyolefin
B7	* MIL-I-81765/TYPE I	Semi-rigid flame retarded polyolefin
G	* VG 95343 PART 6	Fluid resistant elastomer
H	NAVSEA 5617649	Flexible limited fire hazard material

ADHESIVE COATING OPTIONS

Reference	Description
WM250	General purpose hot melt +80°C
W8	High performance hot melt +105°C
W24	1 Part Epoxy 200°C

* Standard products and material.

For ordering procedure – refer to page 5

1300 SERIES

45° ANGLE
T SHAPES - VG STYLE



This style provides strain relief, sealing and mechanical protection on cable harnesses.

VG shapes according to T09 add 'P' after Hellermann part number.

Hellermann Part No.	Angle
1301-1	45°
1302-1	45°
1303-1	45°
1311-1	30°

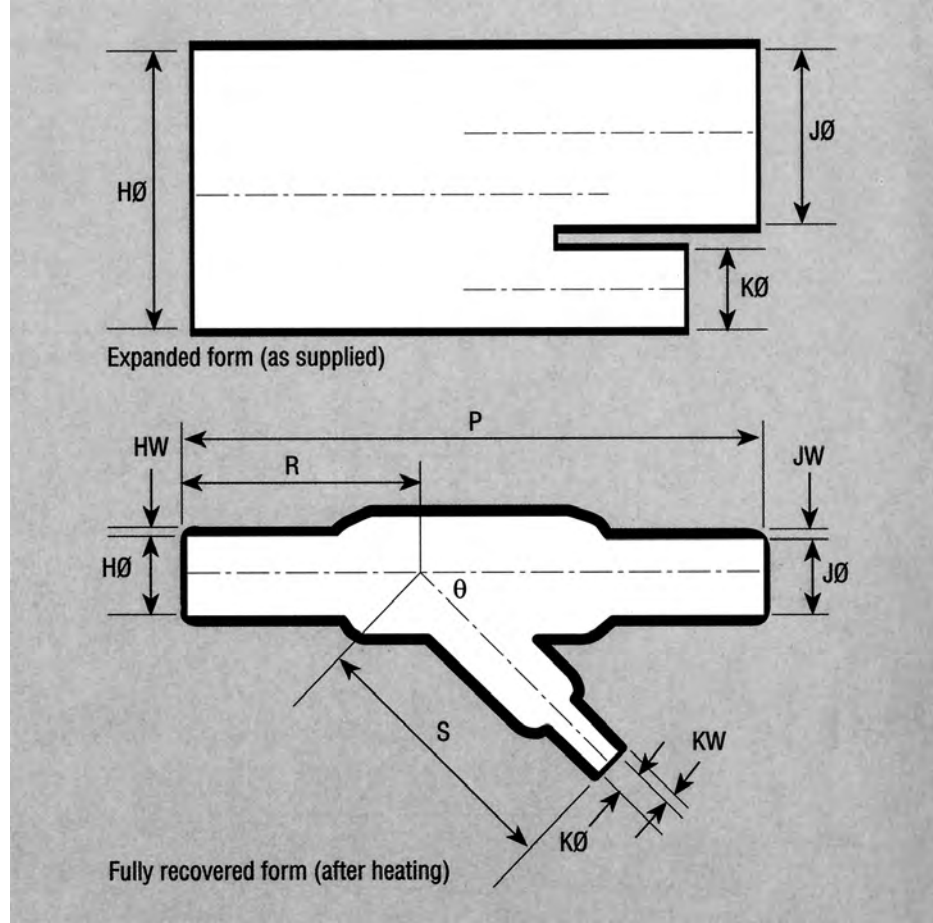

Dimensions apply to all materials unless otherwise indicated and are in inches.

VG Part No.	Hellermann Part No.	Expanded (Min)			Recovered (Max)			Recovered dimensions fully shrunk					
		H	J	K	H	J	K	P ±10%	R ±10%	S ±10%	HW ±20%	JW ±20%	KW ±20%
VG 95343 T08 B001A	* 1301-1	0.51	0.51	0.28	0.28	0.28	0.14	1.97	0.91	0.91	0.06	0.06	0.04
VG 95343 T08 B004A	* 1302-1	1.06	1.06	0.28	0.51	0.51	0.14	3.62	1.61	1.42	0.10	0.10	0.04
VG 95343 T08 B002A	* 1303-1	1.06	1.06	0.51	0.55	0.55	0.30	5.71	2.76	2.13	0.10	0.10	0.06
VG 95343 T08 B003A	* 1311-1	1.20	1.20	0.80	0.59	0.59	0.39	3.25	1.26	2.01	0.10	0.10	0.07

MATERIALS AVAILABLE

Reference	Specification	Description
J	* MIL-I-81765/TYPE II	Flexible modified polyolefin
B7	* MIL-I-81765/TYPE I	Semi-rigid flame retarded polyolefin
G	* VG 95343 PART 6	Fluid resistant elastomer
H	NAVSEA 5617649	Flexible limited fire hazard material

ADHESIVE COATING OPTIONS

Reference	Description
WM250	General purpose hot melt +80°C
W8	High performance hot melt +105°C
W24	1 Part Epoxy 200°C

* Standard products and material.

For ordering procedure – refer to page 5

1300 SERIES

45° ANGLE
T SHAPE - VG STYLE

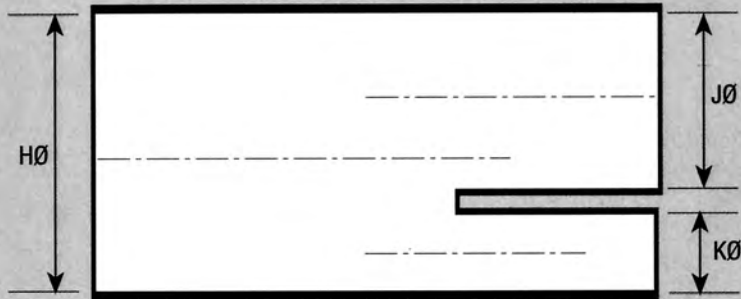
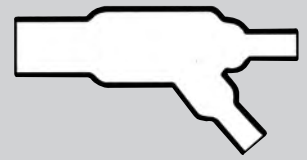

Expanded form (as supplied)

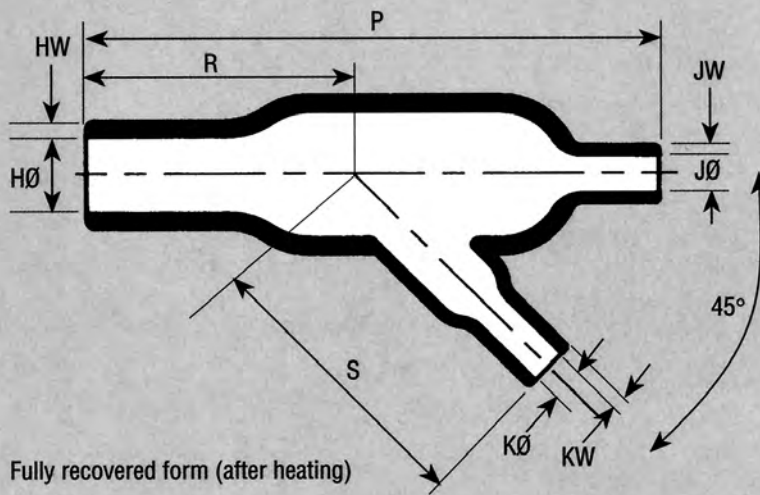

Fully recovered form (after heating)

This style provides strain relief, sealing and mechanical protection on cable harness.

Dimensions apply to all materials unless otherwise indicated and are in inches.

VG Part No.	Hellermann Part No.	Expanded (Min)			Recovered (Max)			Recovered dimensions fully shrunk					
		H	J	K	H	J	K	P ±10%	R ±10%	S ±10%	HW ±20%	JW ±20%	KW ±20%
VG 95343 T08 B010A	* 1306-1	0.51	0.26	0.26	0.24	0.12	0.12	1.77	0.91	0.83	0.06	0.04	0.04
VG 95343 T08 B011A	* 1307-1	1.06	0.51	0.51	0.49	0.24	0.24	3.54	1.65	1.69	0.10	0.06	0.06

MATERIALS AVAILABLE

Reference	Specification	Description
J	* MIL-I-81765/TYPE II	Flexible modified polyolefin
B7	* MIL-I-81765/TYPE I	Semi-rigid flame retarded polyolefin
G	* VG 95343 PART 6	Fluid resistant elastomer
H	NAVSEA 5617649	Flexible limited fire hazard material

ADHESIVE COATING OPTIONS

Reference	Description
WM250	General purpose hot melt +80°C
W8	High performance hot melt +105°C
W24	1 Part Epoxy 200°C

*Standard products and material.

For ordering procedure – refer to page 5

1310 SERIES

30° ANGLE
DOUBLE T SHAPE



This special style provides strain relief, sealing and mechanical protection on cable harness.

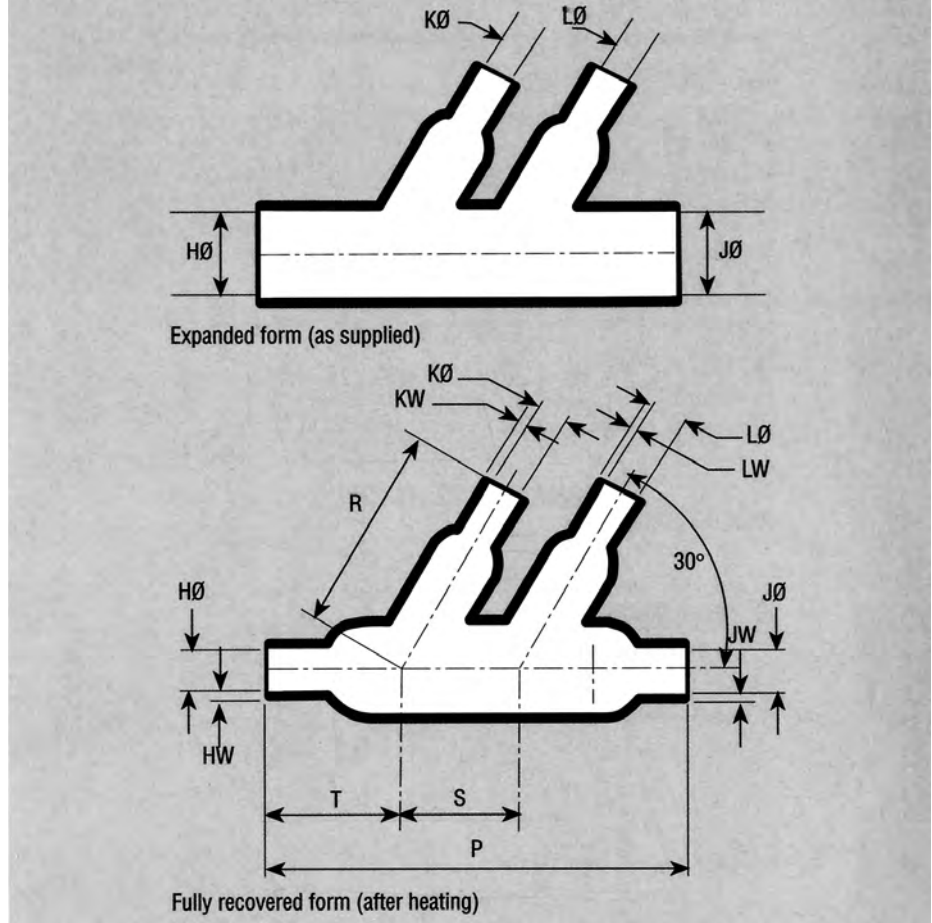

Dimensions apply to all materials unless otherwise indicated and are in inches.

Hellermann Part No.	Expanded (Min)		Recovered (Max)		Recovered dimensions fully shrunk					
	H, J	K, L	H, J	K, L	P ±10%	R ±10%	S ±10%	T ±10%	HW, JW ±20%	KW, LW ±20%
1310-1	1.20	0.50	0.60	0.25	3.50	2.00	1.00	0.75	0.10	0.05

MATERIALS AVAILABLE		
Reference	Specification	Description
J	* MIL-I-81765/TYPE II	Flexible modified polyolefin
B7	* MIL-I-81765/TYPE I	Semi-rigid flame retarded polyolefin
G	* VG 95343 PART 6	Fluid resistant elastomer
H	NAVSEA 5617649	Flexible limited fire hazard material

ADHESIVE COATING OPTIONS	
Reference	Description
WM250	General purpose hot melt +80°C
W8	High performance hot melt +105°C
W24	1 Part Epoxy 200°C

* Standard material.

For ordering procedure – refer to page 5

1400 SERIES

90° ANGLE ELBOW SHAPES



Expanded form (as supplied)

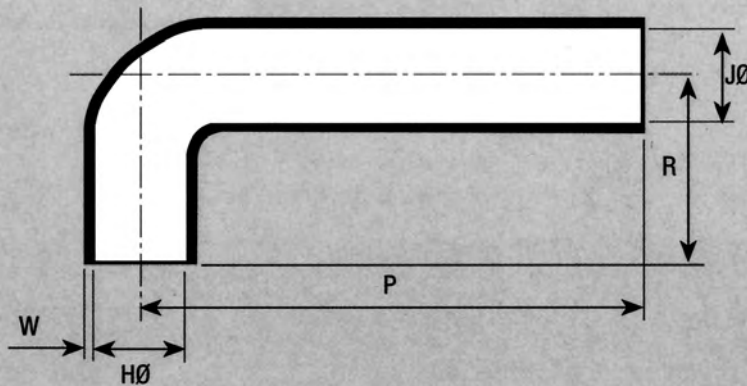

Fully recovered form (after heating)

This style provides cable strain relief and mechanical protection.

Dimensions apply to all materials unless otherwise indicated and are in inches.

Hellermann Part No.	Expanded (Min)		Recovered (Max)		Recovered dimensions fully shrunk		
	H	J	H	J	P ± 10%	R ± 10%	W ± 20%
* 1401-1	1.25	1.25	0.62	0.62	3.50	2.00	0.09
1401-2	1.50	1.50	0.62	0.62	3.50	2.00	0.09
* 1403-1	0.62	0.62	0.31	0.31	1.75	1.00	0.06
1405-1	0.98	0.98	0.31	0.31	1.18	0.59	0.06
1406-1	0.79	0.79	0.31	0.31	1.77	0.59	0.06
* 1408-2	0.75	0.75	0.35	0.35	1.77	1.77	0.07

MATERIALS AVAILABLE

Reference	Specification	Description
J	* MIL-I-81765/TYPE II	Flexible modified polyolefin
B7	* MIL-I-81765/TYPE I	Semi-rigid flame retarded polyolefin
G	* VG 95343 PART 6	Fluid resistant elastomer
H	NAVSEA 5617649	Flexible limited fire hazard material

ADHESIVE COATING OPTIONS

Reference	Description
WM250	General purpose hot melt +80°C
W8	High performance hot melt +105°C
W24	1 Part Epoxy 200°C

* Standard products and material.

For ordering procedure – refer to page 5

1500 SERIES CONNECTOR COVER FOR MIN-D SERIES WITH TOP ENTRY



This style provides strain relief and mechanical protection.

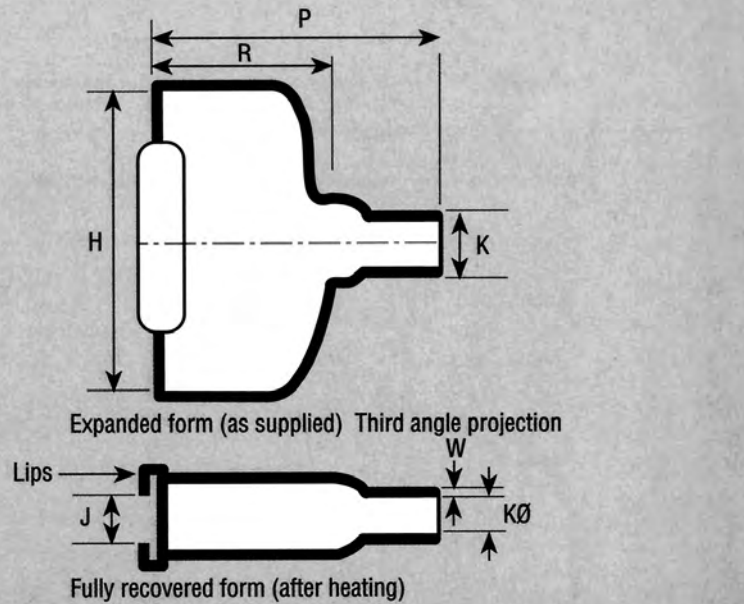

Dimensions apply to all materials unless otherwise indicated and are in inches.

WITH LIPS	Expanded (Min)			Recovered (Max)			Recovered dimensions fully shrunk			Connector Size No. of Ways
	H	J	K	H	J	K	P ±10%	R ±10%	W ±10%	
Hellermann Part No.										
1505-1	0.80	0.42	0.31	0.80	0.42	0.16	1.30	0.75	0.04	9
1505-2	0.63	0.63	0.63	0.80	0.42	0.16	1.30	0.75	0.04	9
1505-7	0.80	0.59	0.47	0.80	0.42	0.16	1.89	0.75	0.04	9
1505-8	0.63	0.63	0.63	0.80	0.42	0.16	1.89	0.75	0.04	9
1506-1	1.11	0.42	0.40	1.11	0.42	0.21	1.53	0.87	0.04	15
1506-2	0.75	0.75	0.75	1.11	0.42	0.21	1.53	0.87	0.04	15
1506-5	1.46	0.42	0.40	1.11	0.42	0.21	1.53	0.87	0.04	15
* 1507-1	1.66	0.42	0.55	1.66	0.42	0.32	1.77	1.00	0.04	25
* 1507-2	1.15	1.15	1.15	1.66	0.42	0.32	1.77	1.00	0.04	25
1507-7	2.17	0.55	0.98	1.66	0.42	0.32	1.77	1.00	0.04	25
1501-1	2.30	0.42	0.68	2.31	0.42	0.34	2.10	1.12	0.04	37
1501-2	1.35	1.35	1.35	2.31	0.42	0.34	2.10	1.12	0.04	37
1502-1	1.48	1.48	1.48	2.28	0.54	0.41	2.40	1.25	0.04	50
1502-2	2.28	0.54	0.75	2.28	0.54	0.41	2.40	1.25	0.04	50

WITHOUT LIPS	H	J	K	H	J	K	P ±10%	R ±10%	W ±10%	Connector Size No. of Ways
1505-3	0.83	0.49	0.31	0.80	0.42	0.16	1.30	0.75	0.04	9
* 1507-3	1.66	0.42	0.55	1.66	0.42	0.32	1.77	1.00	0.04	25
1501-3	2.35	0.49	0.68	2.31	0.42	0.34	2.10	1.12	0.04	37
1501-7	2.30	0.42	0.68	2.31	0.42	0.34	2.10	1.12	0.04	37
1502-3	2.26	0.54	0.75	2.28	0.54	0.41	2.40	1.25	0.04	50

MATERIALS AVAILABLE

Reference	Specification	Description
J	* MIL-I-81765/TYPE II	Flexible modified polyolefin
B7	* MIL-I-81765/TYPE I	Semi-rigid flame retarded polyolefin
G	* VG 95343 PART 6	Fluid resistant elastomer
H	NAVSEA 5617649	Flexible limited fire hazard material

ADHESIVE COATING OPTIONS

Reference	Description
WM250	General purpose hot melt +80°C
W8	High performance hot melt +105°C
W24	1 Part Epoxy 200°C

* Standard products and material.

1600 SERIES

END CAPS

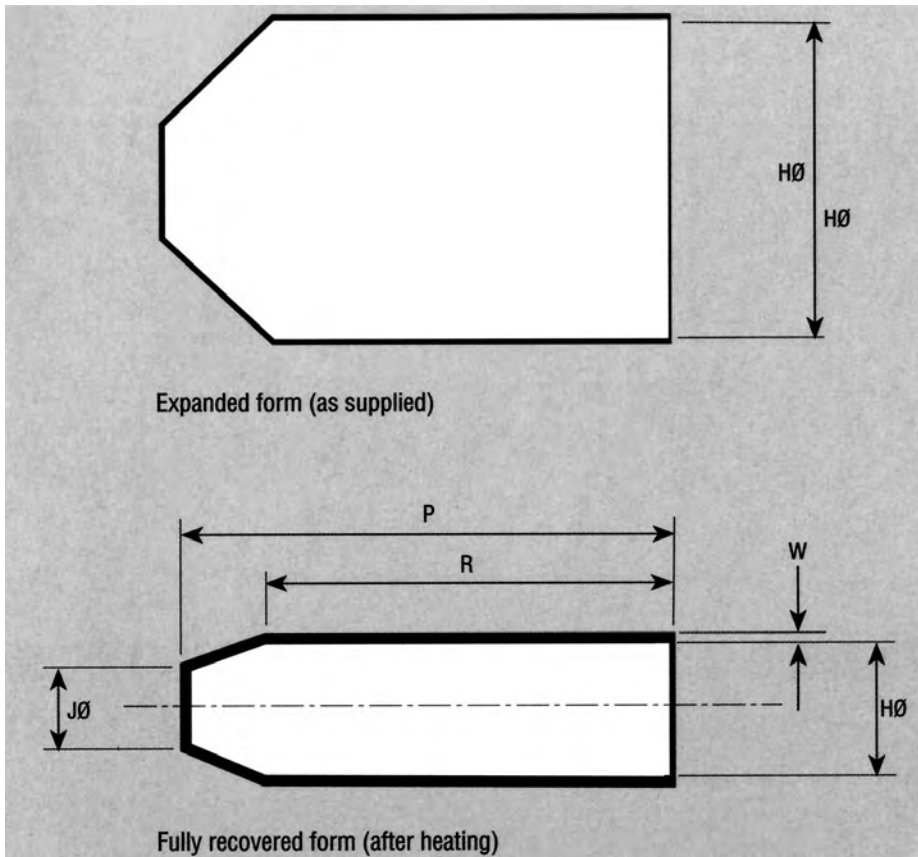

This style has a conical end and is used for sealing cables.

End caps with the exception of 1612, 1618 and 1633 can be fitted with air valves for certain pressurized cable applications. Consult your master distributor for availability.

Dimensions apply to all materials unless otherwise indicated and are in inches.

Hellermann Part No.	Exp'd (Min)	Recovered (Max)		Recovered dimensions fully shrunk			
	H	H	J	P ±10%	R ±10%	W ±20%	For Cable Diameters
* 1612-1	0.39	0.16	0.12	1.32	1.18	0.08	0.16-0.31
1618-1	0.55	0.24	0.20	2.18	1.97	0.09	0.24-0.43
* 1613-1	0.79	0.30	0.26	2.18	1.97	0.09	0.31-0.63
* 1614-1	1.57	0.59	0.41	3.54	3.15	0.12	0.60-1.26
1620-1	1.38	0.50	0.39	7.25	7.05	0.13	0.51-1.10
* 1615-1	2.48	0.98	0.63	5.64	5.12	0.13	0.98-1.97
* 1617-1	2.99	1.18	0.67	6.22	5.91	0.16	1.18-2.36
* 1616-1	3.94	1.77	1.02	6.40	5.51	0.16	1.77-3.15
1609-1	4.72	2.36	0.67	5.91	5.24	0.16	60.0-96.0
1610-1	6.30	3.23	1.06	5.75	4.57	0.16	82.0-128

MATERIALS AVAILABLE		
Reference	Specification	Description
J	MIL-I-81765/TYPE II	Flexible modified polyolefin
B7	MIL-I-81765/TYPE I	Semi-rigid flame retarded polyolefin
G	VG 95343 PART 6	Fluid resistant elastomer
B8	*	Semi-rigid polyolefin

ADHESIVE COATING OPTIONS	
Reference	Description
W	General purpose hot melt +80°C

* Standard products and material.

For ordering procedure – refer to page 5

1750 SERIES

GSR - GRADUATED STRAIN RELIEF SHAPES

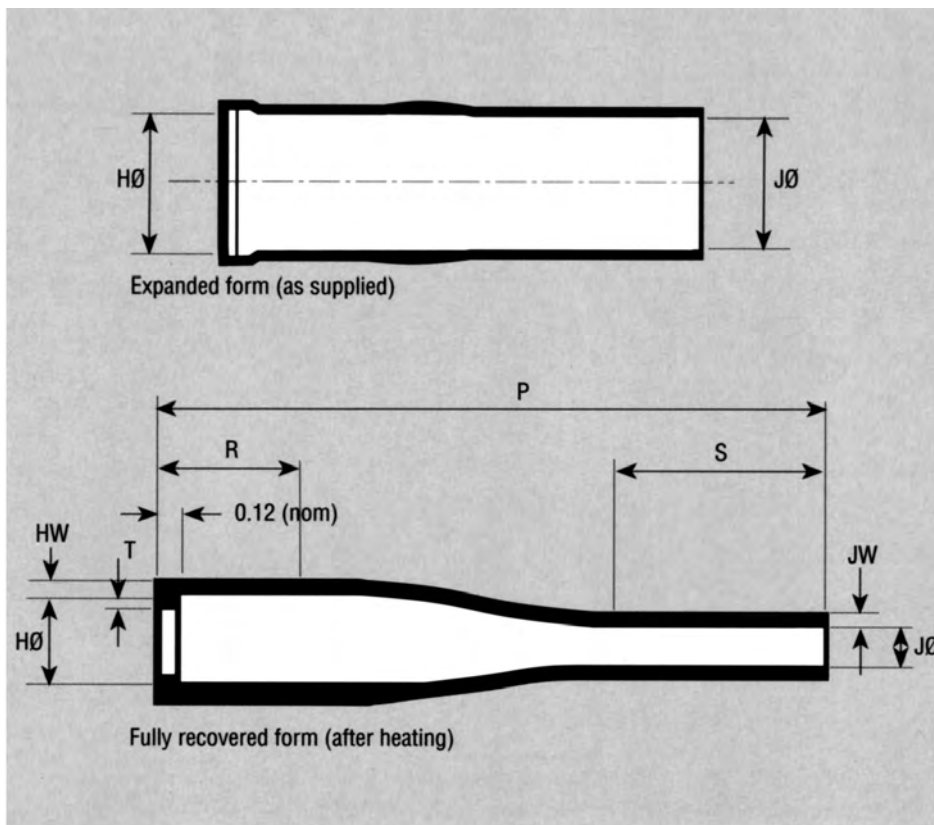

This style is ideally suited for shipboard and railway carriage cabling.

Key Features:

- Very robust
- Superior crush resistance
- Excellent strain relief
- Wall thickness varies with long thin tail allowing setting at varying angles through to 90°

Dimensions apply to all materials unless otherwise indicated and are in inches.

NAVSEA REFERENCE	Hellermann Part No.	Expanded (Min)		Recovered (Max)		Recovered dimensions fully shrunk					
		H	J	H	J	P ±10%	R ±10%	S ±10%	T ±10%	HW ±20%	JW ±20%
5617649-1	1751-1	1.00	1.00	0.65	0.33	6.02	1.20	1.89	0.06	0.16	0.06
—	1751-2	1.30	1.30	0.65	0.33	6.02	1.20	1.89	0.06	0.16	0.06
5617649-2	1752-1	1.30	1.30	0.80	0.43	6.02	1.20	1.89	0.06	0.16	0.06
—	1752-2	1.70	1.70	0.80	0.43	6.02	1.20	1.89	0.06	0.16	0.06
5617649-3	1753-1	1.70	1.70	0.90	0.56	6.90	1.50	1.89	0.06	0.16	0.08
—	1753-2	2.10	2.10	0.90	0.56	6.90	1.50	1.89	0.06	0.16	0.08
5617649-4	1754-1	2.10	2.10	1.10	0.70	6.90	1.50	1.89	0.06	0.16	0.08
—	1754-2	2.85	2.85	1.10	0.70	6.90	1.50	1.89	0.06	0.16	0.08
5617649-5	1755-1	2.85	2.85	1.45	0.95	7.24	1.61	2.01	0.06	0.20	0.10
—	1755-2	3.43	3.43	1.45	0.95	7.24	1.61	2.01	0.06	0.20	0.10

MATERIALS AVAILABLE		
Reference	Specification	Description
J	MIL-I-81765/TYPE II	Flexible modified polyolefin
B7	MIL-I-81765/TYPE I	Semi-rigid flame retarded polyolefin
G	VG 95343 PART 6	Fluid resistant elastomer
H	* NAVSEA 5617649	Flexible limited fire hazard material

ADHESIVE COATING OPTIONS	
Reference	Description
WM250	General purpose hot melt +80°C
W8	High performance hot melt +105°C
W24	1 Part Epoxy 200°C

* Standard material.

For ordering procedure – refer to page 5

1800 SERIES

ANGLE SHAPES WITH RIB

30°, 45° & 60°



This style provides strain relief, mechanical protection for harness systems when used in conjunction with a circular grooved adaptor.

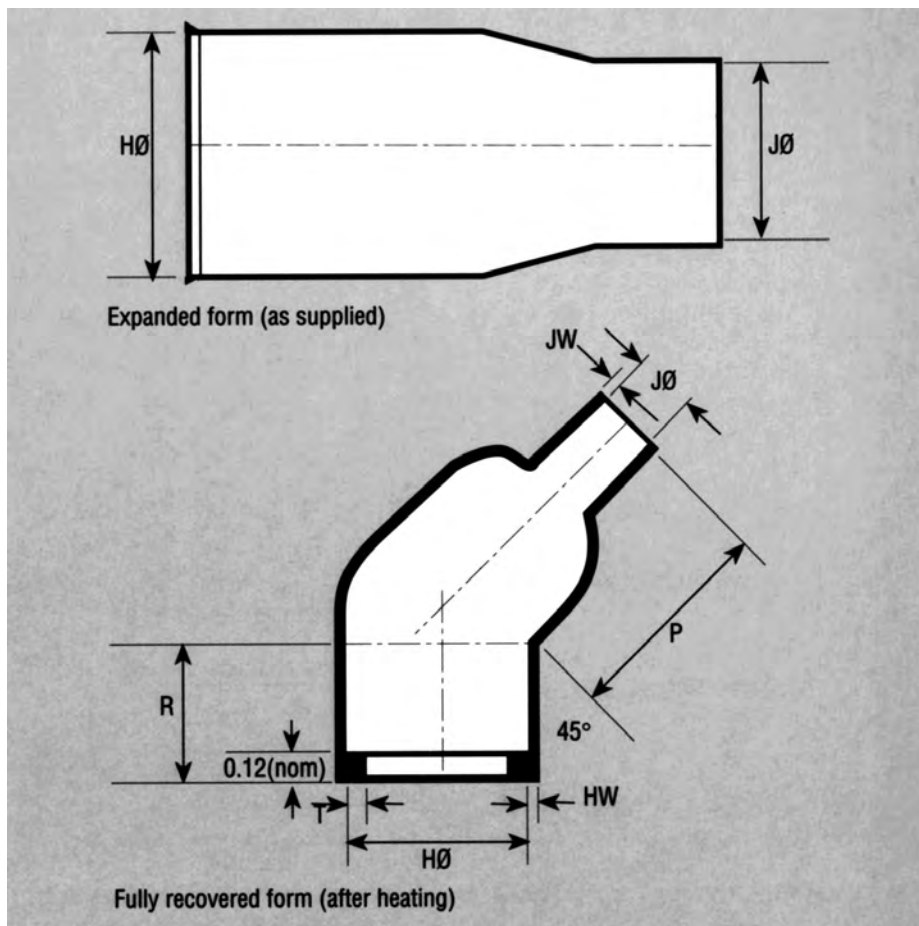

Dimensions apply to all materials unless otherwise indicated and are in inches.

Angle Nominal	Hellermann Part No.	Expanded (Min)				Rec'd (Max)		Recovered dimensions fully shrunk				
		H	H -H Matl	J	J -H Matl	H	J	P ±10%	R ±10%	T ±10%	HW ±10%	JW ±20%
45°	1807-4	1.40	1.40	1.40	0.87	0.71	0.29	1.70	0.40	0.04	0.07	0.07
45°	1805-4	1.57	1.57	1.57	0.83	0.74	0.28	1.10	0.43	0.04	0.06	0.06
45°	1806-4	1.68	1.68	1.68	1.15	1.10	0.38	3.35	0.70	0.07	0.08	0.08
45°	1821-42	0.79	0.79	0.79	0.47	0.56	0.16	0.95	0.39	0.04	0.09	0.07

MATERIALS AVAILABLE

Reference	Specification	Description
J	* MIL-I-81765/TYPE II	Flexible modified polyolefin
B7	* MIL-I-81765/TYPE I	Semi-rigid flame retarded polyolefin
G	* VG 95343 PART 6	Fluid resistant elastomer
H	NAVSEA 5617649	Flexible limited fire hazard material

ADHESIVE COATING OPTIONS

Reference	Description
WM250	General purpose hot melt +80°C
W8	High performance hot melt +105°C
W24	1 Part Epoxy 200°C

* Standard material.

For ordering procedure – refer to page 5

2000 SERIES

RIGHT-ANGLE CROSS SHAPE

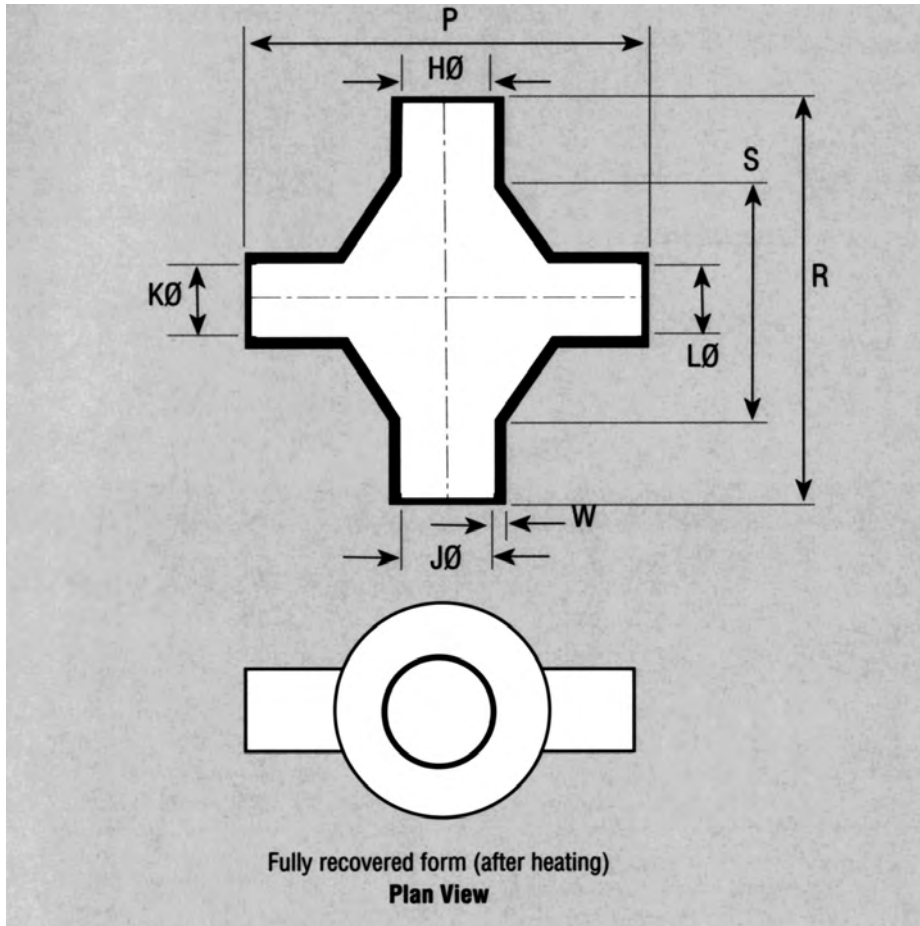
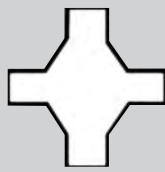

This style provides environmental sealing, mechanical protection, allowing wires to be routed in four 90° directions.

Dimensions apply to all materials unless otherwise indicated and are in inches.

Hellermann Part No.	Expanded (Min)		Rec'd (Max)		Recovered dimensions fully shrunk			
	H, J	K, L	H, J	K, L	P ±10%	R ±10%	S ±10%	W ±10%
2003-1	0.76	0.52	0.38	0.24	1.50	1.50	0.87	0.04

MATERIALS AVAILABLE

Reference	Specification	Description
J	MIL-I-81765/TYPE II	Flexible modified polyolefin
B7	* MIL-I-81765/TYPE I	Semi-rigid flame retarded polyolefin
G	* VG 95343 PART 6	Fluid resistant elastomer
H	NAVSEA 5617649	Flexible limited fire hazard material

ADHESIVE COATING OPTIONS

Reference	Description
WM250	General purpose hot melt +80°C
W8	High performance hot melt +105°C
W24	1 Part Epoxy 200°C

* Standard material.

For ordering procedure – refer to page 5

1760, 1790, 1820 SERIES LOCATING BUSHES



This style provides location, cushioning shimming and protection on cable lengths.

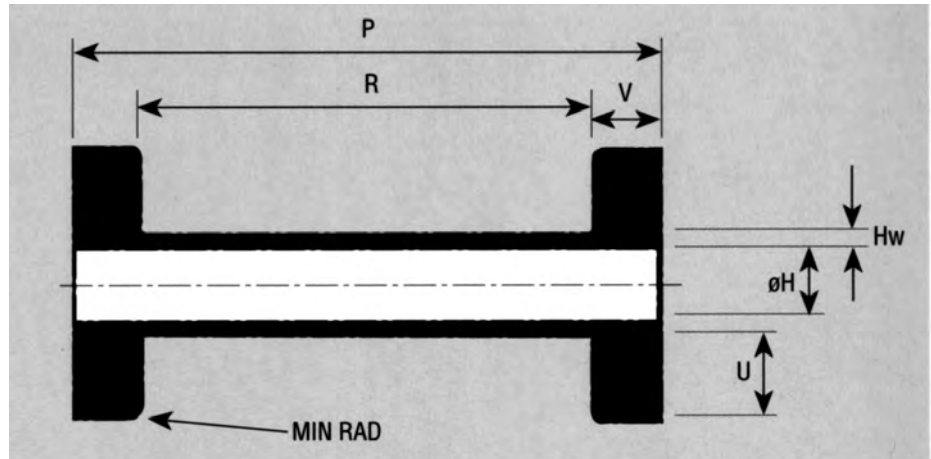

Dimensions apply to all materials unless otherwise indicated and are in inches.

Hellermann Part No.	Expanded (Min)		Rec'd (Max)		Recovered dimensions fully shrunk				
	H Min	H Max	P ±10%	R ±10%	U ±10%	V ±10%	Hw ±20%		
1793-3	1.26	0.37	1.38	1.00	0.12	0.18	0.060		
1794-3	1.42	0.71	1.38	1.00	0.12	0.18	0.080		
1795-3	1.58	0.50	1.38	1.00	0.12	0.18	0.080		
1796-3	0.86	0.25	1.14	0.95	0.08	0.98	0.06		

This style suits non round cable bundles

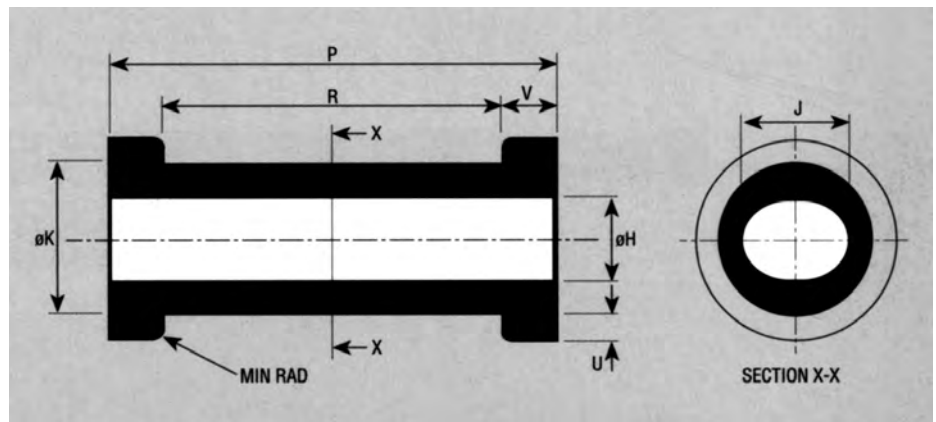

Dimensions apply to all materials unless otherwise indicated and are in inches.

Hellermann Part No.	Expanded (Min)		Rec'd (Max)		Recovered dimensions fully shrunk				
	H Min	J Min	H Max	J Max	K ±10%	P Max	R ±10%	U ±10%	V ±10%
1822-2	0.47	0.47	0.23	0.40	0.47	1.18	0.95	0.08	0.19
1823-3	0.63	0.63	0.30	0.48	0.55	1.26	0.95	0.098	0.16

MATERIALS AVAILABLE

Reference	Specification	Description
J	MIL-I-81765/TYPE II	Flexible modified polyolefin
B7	* MIL-I-81765/TYPE I	Semi-rigid flame retarded polyolefin
G	* VG 95343 PART 6	Fluid resistant elastomer
H	NAVSEA 5617649	Flexible limited fire hazard material

ADHESIVE COATING OPTIONS

Reference	Description
WM250	General purpose hot melt +80°C
W8	High performance hot melt +105°C
W24	1 Part Epoxy 200°C

* Standard material.

For ordering procedure – refer to page 5

2100 SERIES CONNECTOR COVER FOR MIN D SERIES WITH 90° ENTRY

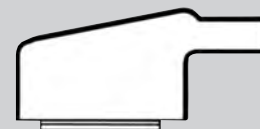

This style provides strain relief and mechanical protection.

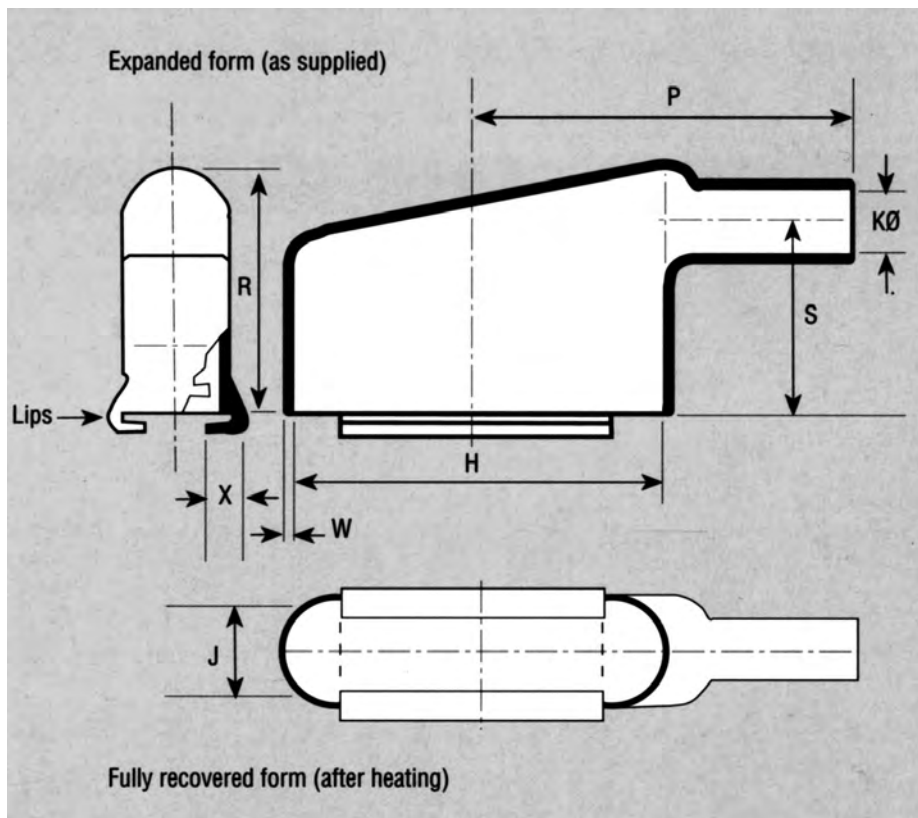

Dimensions apply to all materials unless otherwise indicated and are in inches.

HELLERMANN PART NO.	WITH LIPS						Expanded (Min)			Recovered (Max)			Recovered dimensions fully shrunk					Connector size No. of ways
	H	H -H Matl	J	J -H Matl	K	K -H Matl	H	J	K	S ±10%	P ±10%	R ±10%	X ±10%	W ±20%				
2101-1	0.80	0.80	0.42	0.42	0.31	0.31	0.80	0.42	0.16	0.60	1.02	0.85	0.12	0.04	9			
2101-2	0.63	0.48	0.63	0.48	0.63	0.48	0.80	0.42	0.16	0.60	1.02	0.85	0.12	0.04	9			
2102-1	1.11	1.11	0.42	0.42	0.40	0.40	1.11	0.42	0.21	0.73	1.21	0.97	0.12	0.04	15			
2102-2	0.75	0.63	0.75	0.63	0.75	0.63	1.11	0.42	0.21	0.73	1.21	0.97	0.12	0.04	15			
2103-1	1.66	1.66	0.42	0.42	0.55	0.63	1.66	0.42	0.29	0.87	1.69	1.10	0.12	0.04	25			
2103-2	1.15	0.87	1.15	0.87	1.15	0.87	1.66	0.42	0.29	0.87	1.69	1.10	0.12	0.04	25			
2104-1	2.31	2.31	0.42	0.42	0.68	0.68	2.31	0.42	0.34	1.00	2.10	1.20	0.12	0.04	37			
2105-1	2.28	2.28	0.54	0.54	0.75	0.75	2.28	0.54	0.42	1.00	2.20	1.27	0.12	0.04	50			
2105-2	1.48	1.26	1.48	1.26	1.48	1.26	2.28	0.54	0.42	1.00	2.20	1.27	0.12	0.04	50			

HELLERMANN PART NO.	WITHOUT LIPS						Expanded (Min)			Recovered (Max)			Recovered dimensions fully shrunk					Connector size No. of ways
	H	H -H Matl	J	J -H Matl	K	K -H Matl	H	J	K	S ±10%	P ±10%	R ±10%	X ±10%	W ±20%				
2103-3	1.69	1.69	0.49	0.49	0.55	0.55	1.66	0.42	0.29	0.87	1.69	1.10	0.12	0.04	25			
2105-3	2.26	2.26	0.60	0.60	0.75	0.75	2.28	0.54	0.42	1.00	2.20	1.27	0.12	0.04	50			

MATERIALS AVAILABLE

Reference	Specification	Description
J	MIL-I-81765/TYPE II	Flexible modified polyolefin
B7	MIL-I-81765/TYPE I	Semi-rigid flame retarded polyolefin
G	VG 95343 PART 6	Fluid resistant elastomer
H	NAVSEA 5617649	Flexible limited fire hazard material

ADHESIVE COATING OPTIONS

Reference	Description
WM250	General purpose hot melt +80°C
W8	High performance hot melt +105°C
W24	1 Part Epoxy 200°C

For ordering procedure – refer to page 5

VG/MIL SPEC CROSS REFERENCE

Products listed below in VG Style or MIL Spec Style can be substituted with each other, to achieve similar fit and function.

VG Parts	MIL Spec Parts
152-42	105-4
153-42	N/A
154-42	106-4
155-42	101-4
156-42	102-4
157-43	103-4
158-43	107-4
159-43	118-4
1152-4	1106-4
1154-4	1107-4
1155-4	1104-4
1156-4	1103-4
1157-4	1101-4
1158-4	1105-4
1159-4	1109-4
129-1	129-4
130-1	130-4
131-1	131-4
132-1	132-4
133-1	133-4
134-1	134-4
135-1	135-4
136-1	136-4
138-1	138-4
187-1	187-4
1122-1	1122-4
1123-1	1123-4
1124-1	1124-4
1125-1	1125-4
1126-1	1126-4
1127-1	1127-4
1128-1	1128-4
1129-1	1129-4

Note:-
These have a
longer overall
length than
VG parts

HOT MELT ADHESIVE TAPE

Hot melt adhesive is available as tape and is designed to be used primarily in conjunction with heatshrinkable tubing and moulded shapes in order to provide sealant / adhesive action at the interface between the encapsulant and the substrate.

The adhesive is a specially compounded blend of resins which melts below the shrinkage temperature of heat shrinkable polyolefin products (+135°C) and also bonds to the polyolefin surface and the wide variety of substrate surfaces to which it is applied, eg cable jackets, metal sheaths and connector back shells. HMT200A will maintain its adhesive sealant properties from -55° to +105°C.

Method of application

Tape form HMT200A. Nominal dimensions 1.00 inch wide, 0.01 inch thick, nominally 100ft per reel.

1. Substrate surfaces should be clean and free from grease and dirt. If necessary, wipe with a suitable solvent.
2. The substrate should be pre-warmed to reduce its effect as a heat sink.
3. The HMT200A tape should be wrapped once, under slight tension, around the warm substrate with a minimum overlap. When soft it can be pressed into position.
4. Heatshrink is then placed over the assembly and recovered by heating.
5. After the component has been recovered, heating must be continued to ensure that the tape has completely melted, thus ensuring correct bonding.
6. Any rearrangement of the assembly after the heat-shrinkable component has been positioned must be done whilst the sealant is still molten and the encapsulation is above 120°C. Once set, no stresses should be applied to the assembly until it has completely cooled.

Note:

1. Substrates with considerable heat sink characteristics should be pre-warmed. This type of assembly may require even longer post-shrinkage heating to ensure that the HMT200A tape has melted.

HMT200A is a hot melt adhesive tape which is designed for use with heatshrink tubing and mouldings. The adhesive tape flows when heated to provide a permanent air and water tight seal.

Typical Properties		TSA200TAPE	HMT200A
Operating Temperature		-55°C to +125°C	-55°C to +105°C
Softening Point		N/A	+110°C
Peel Strength	XLPE/Metal	35lbs/inch	33lbs/inch
	XLPE/XLPE	25lbs/inch	18lbs/inch
	PVC/PVC	13lbs/inch	13lbs/inch
Lap Shear Strength	XLPE/Metal	60lbs	55lbs
	XLPE/XLPE	55lbs	36lbs
Shelf Life		2 Years	2 Years
Colours:		Natural	Natural

Installation guide for TSA200 tape on request

V9500 EPOXY ADHESIVE

Availability

V9500 epoxy adhesive is available in two forms:

- 1) 1x duo Pak (50g), 5x mixing pots, 5x mixing sticks, 5, emery papers order V9500 Epoxy adhesive kit.
- 2) 50gm twin plunger Duo Pak with mixing crucibles, emery cloth and spatulas. Order ref V9500 DP KIT.

Hellermann Duo Pak is ideal for volume applications. Features include:

- Accurate dispensing - no need for any weighing of components.
- No mixing is necessary when using the nozzle.
- Less adhesive waste.
- Unique end cap assures proper sealing for multiple uses.
- Contains 50gms equivalent to 5 x 10gm sachets.
- Positive locking of mixing nozzle.

V 9500 Nozzle New

V 9500 DUO PAK

V 9500 Applicator

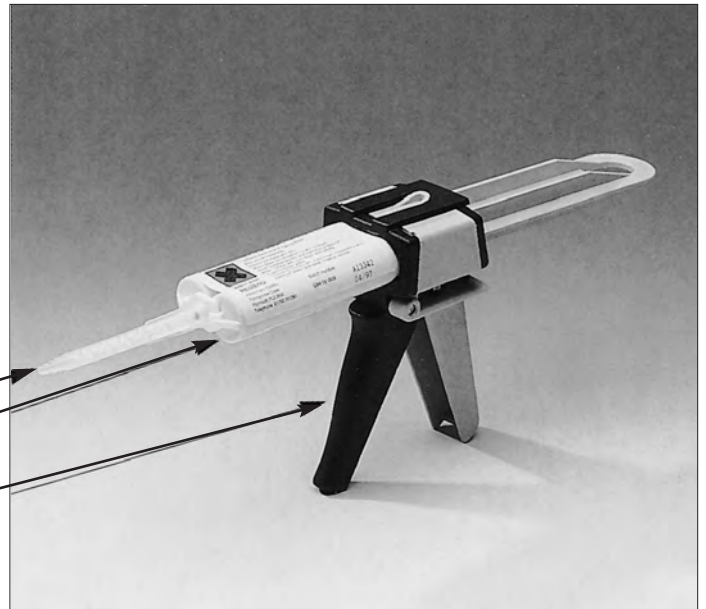

Shelf Life:

The product should be stored in its original packaging at temperatures between +14°C – +26°C. Minimum shelf life of 18 months.

For applications of adhesive see the code of practice which is available from your master distributor.

Qualified to VG 95343 T15A0001.

Part Numbers

V9500 DUO PACK	50gm twin plunger Duo Pak
V9500 NOZZLE NEW	Nozzle for 50gm twin plunger
V9500 APPLICATOR	Applicator for V9500 DUO PAK
V9500 DP Kit	50gm twin plunger Duo pak with mixing crucibles, emery cloth and spatulas

BOTTLE SHAPES FOR MIL CONNECTORS

HELLERMANN SHAPES FOR USE WITH CIRCULAR MIL SPEC CONNECTORS MS 5015 AB/LITTON ETC.



Connector Shell Size	O/Knurl Dia (inches)	Orientation		Cable Dia (inches)	
		Straight	90°	Min	Max
*10 SL	0.62	153-42	*1152-4/1106-4	*0.16	0.30
14 S	0.76	154-42/106-4	1154-4/1107-4	0.28	0.42
16 S	0.95	155-42/101-4	1155-4/1104-4	0.33	0.53
16	0.95	155-42/101-4	1155-4/1104-4	0.33	0.53
18	0.95	155-42/101-4	1155-4/1104-4	0.33	0.57
20	1.17	156-42/102-4	1156-4/1103-4	0.40	0.74
22	1.17	156-42/102-4	1156-4/1103-4	0.40	0.82
24	1.49	157-43/103-4	1157-4/1101-4	0.47	0.97
28	1.49	157-43/103-4	1157-4/1101-4	0.47	1.06
32	1.89	158-43/107-4	1158-4/1105-4	0.76	1.31
36	1.89	158-43/107-4	1158-4/1105-4	0.76	1.51

* Note: Shell 10 SL for 90° moulded part min cable diameter 0.260 inches

HELLERMANN SHAPES FOR USE WITH MIL-C-26482-I/II and 38999/SERIES I, II, III, IV

Connector Shell Size	O/Knurl Dia (inches)	Orientation		Cable Dia (inches)	
		Straight	90°	Min	Max
8/9	0.51	152-42/105-4	1152-4/1106-4	0.28	0.27
10/11	0.60	152-42/105-4	1152-4/1106-4	0.28	0.40
10/12	0.60/0.75	153-42/NA	—	0.16	0.40
12/13	0.75	154-42/106-4	1154-4/1107-4	0.28	0.53
14/15	0.82	155-42/101-4	1155-4/1104-4	0.33	0.64
16/17	0.94	155-42/101-4	1155-4/1104-4	0.33	0.76
18/19	1.02	156-42/102-4	1156-4/1103-4	0.40	0.86
20/21	1.20	156-42/102-4	1156-4/1103-4	0.40	0.98
22/23	1.34	157-43/103-4	1157-4/1101-4	0.47	1.12
24/25	1.42	157-43/103-4	1157-4/1101-4	0.47	1.22

MIL SPEC SLASH SHEET CROSS REFERENCE BULBOUS SHAPES

MS3109			
105-4-JL	-11AU	Bottle shapes with rib 'J' or 'B7' Material J=Red stripe B7=White stripe Optional drainholes (D)	
105-4-B7L	-11BU		
106-4-JL	-12AU		
106-4-B7L	-12BU		
101-4-JL	-13AU		
101-4-B7L	-13BU		
102-4-JL	-14AU		
102-4-B7L	-14BU		
103-4-JL	-15AU		
103-4-B7L	-15BU		
107-4-JL	-16AU		
107-4-B7L	-16BU		
118-4-JL	-17AU		
118-4-B7L	-17BU		
129-4-JDL	-01AU		
129-4-B7DL	-01BU		
130-4-JDL	-02AU		
130-4-B7DL	-02BU		
131-4-JDL	-03AU		
131-4-B7DL	-03BU		
132-4-JDL	-04AU		
132-4-B7DL	-04BU		
133-4-JDL	-05AU		
133-4-B7DL	-05BU		
134-4-JDL	-06AU		
134-4-B7DL	-06BU		
135-4-JDL	-07AU		
135-4-B7DL	-07BU		
136-4-JDL	-08AU		
136-4-B7DL	-08BU		
138-4-JDL	-09AU		
138-4-B7DL	-09BU		
187-4-JDL	-10AU		
187-4-B7DL	-10BU		
MS3117			
1106-4-JL	-11AU	Right angle shapes with rib 'J' or 'B7' material J=Red stripe B7=White stripe Optional drainholes (D)	
1106-4-B7L	-11BU		
1107-4-JL	-12AU		
1107-4-B7L	-12BU		
1104-4-JL	-13AU		
1104-4-B7L	-13BU		
1103-4-JL	-14AU		
1103-4-B7L	-14BU		
1101-4-JL	-15AU		
1101-4-B7L	-15BU		
1105-4-JL	-16AU		
1105-4-B7L	-16BU		
1109-4-JL	-17AU		
1109-4-B7L	-17BU		
1121-4-JDL	-01AU		
1121-4-B7DL	-01BU		
1122-4-JDL	-02AU		
1122-4-B7DL	-02BU		
1123-4-JDL	-03AU		
1123-4-B7DL	-03BU		
1124-4-JDL	-04AU		
1124-4-B7DL	-04BU		
1125-4-JDL	-05AU		
1125-4-B7DL	-05BU		
1126-4-JDL	-06AU		
1126-4-B7DL	-06BU		
1127-4-JDL	-07AU		
1127-4-B7DL	-07BU		
1128-4-JDL	-08AU		
1128-4-B7DL	-08BU		
1129-4-JDL	-09AU		
1129-4-B7DL	-09BU		
		Right angles shapes Low profile with rib 'J' or 'B7' material J=Red stripe B7=White stripe Supplied with drainholes (D)	

LIMITED FIRE HAZARD BOOT-BACKSHELL ASSEMBLIES

HSK assemblies provide an alternative solution to standard saddle clamps which can corrode over extended use. They provide strain relief and form an environmental seal. The spin coupler allows re-entry to the connector after many years of service.

HSK assembly kits are available in straight or 90°. They mate to connectors according to BS 9522, F0032 and VG 95-234, typically VEAM CIR, Amphenol Series 97, and ABB MS. For assemblies to suit other Mil Spec Connectors and materials, consult your master distributor.

HSK – Straight						
Part No.	Shell Size	J		P +/-10%	Cable Range	
		Min A	Max B		Min	Max
HSK1601	10SL	0.43	0.23	2.72	0.24	0.31
HSK1602	14S	0.51	0.28	3.15	0.29	0.43
HSK1603	16S	0.59	0.33	3.70	0.35	0.51
HSK1604	16	0.59	0.33	3.78	0.35	0.51
HSK1605	18	0.67	0.33	3.70	0.35	0.63
HSK1606	20	0.83	0.39	4.45	0.41	0.71
HSK1607	22	0.91	0.39	4.45	0.41	0.83
HSK1608	24	1.06	0.62	5.67	0.47	0.95
HSK1609	28	1.30	0.62	5.75	0.47	1.06
HSK1610	32	1.58	0.66	7.25	0.69	1.34
HSK1611	36	1.69	0.66	7.25	0.69	1.50
HSK1612	40	2.05	0.66	7.25	0.69	1.73

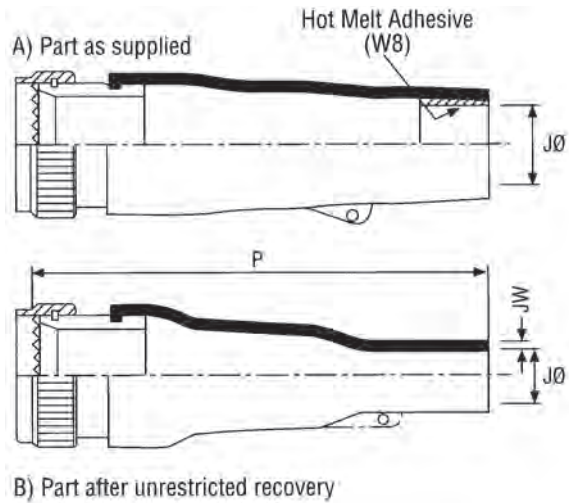

Dimensions apply to all materials unless otherwise indicated and are in inches.

HSK – 90°							
Part No.	Shell Size	J		L +/-10% B	P +/-10% B	Cable Range	
		Min A	Max B			Min	Max
HSK1613	10L	0.43	0.23	1.62	1.26	0.24	0.31
HSK1614	14S	0.51	0.28	1.73	1.54	0.29	0.43
HSK1615	6S	0.59	0.33	2.05	1.81	0.35	0.51
HSK1616	16	0.59	0.33	2.05	1.81	0.35	0.51
HSK1617	18	0.67	0.33	2.05	1.81	0.35	0.63
HSK1618	20	0.83	0.39	2.32	2.17	0.41	0.71
HSK1619	22	0.91	0.39	2.32	2.17	0.41	0.83
HSK1620	24	1.06	0.62	2.68	3.15	0.47	0.95
HSK1621	28	1.30	0.62	2.76	3.15	0.47	1.06
HSK1622	32	1.58	0.66	3.23	4.25	0.69	1.34
HSK1623	36	1.69	0.66	3.23	4.25	0.69	1.50
HSK1624	40	2.05	0.66	3.19	4.25	0.69	1.73

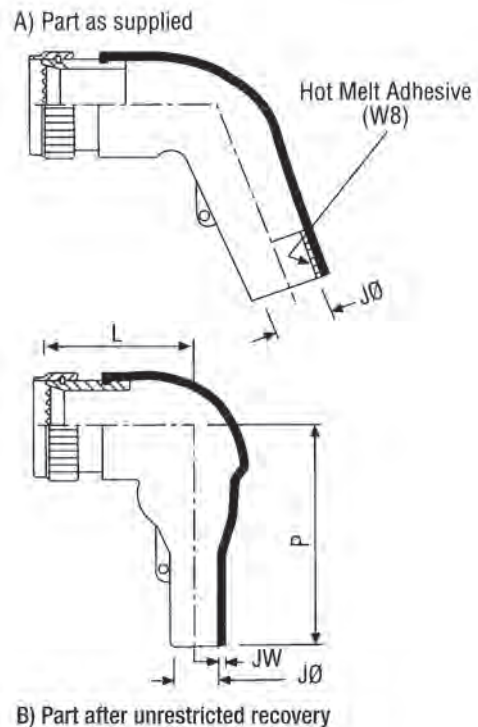

1. HSK assemblies meet the sealing requirements of VG95234.
2. HSK 1601-1624 use -H material.

VG CROSS REFERENCE

HellermannTyton Part Number		HellermannTyton Part Number		HellermannTyton Part Number	
VG Part No.		VG Part No.		VG Part No.	
VG 95343 T06 A001A	152-41-G	VG 95343 T06 F001A	1121-1-G	VG 95343 T07 D001A	129-1-GP
VG 95343 T06 A002A	153-41-G	VG 95343 T06 F002A	1122-1-G	VG 95343 T07 D002A	130-1-GP
VG 95343 T06 A003A	154-41-G	VG 95343 T06 F003A	1123-1-G	VG 95343 T07 D003A	131-1-GP
VG 95343 T06 A004A	155-41-G	VG 95343 T06 F004A	1124-1-G	VG 95343 T07 D004A	132-1-GP
VG 95343 T06 A005A	156-41-G	VG 95343 T06 F005A	1125-1-G	VG 95343 T07 D005A	133-1-GP
VG 95343 T06 A006A	157-41-G	VG 95343 T06 F006A	1126-1-G	VG 95343 T07 D006A	134-1-GP
VG 95343 T06 A007A	158-41-G	VG 95343 T06 F007A	1127-1-G	VG 95343 T07 D007A	135-1-GP
VG 95343 T06 A008A	159-41-G	VG 95343 T06 F008A	1128-1-G	VG 95343 T07 D008A	136-1-GP
VG 95343 T06 A009A	160-41-G	VG 95343 T06 F009A	1129-1-G	VG 95343 T07 D009A	138-1-GP
VG 95343 T06 A010A	199-4-G	VG 95343 T06 F010A	1141-1-G	VG 95343 T07 D010A	187-1-GP
VG 95343 T06 B001A	152-42-G	VG 95343 T06 F011A	1133-1-G	VG 95343 T07 E001A	1152-4-GP
VG 95343 T06 B002A	153-42-G	VG 95343 T06 F012A	1134-1-G	VG 95343 T07 E002A	1154-4-GP
VG 95343 T06 B003A	154-42-G	VG 95343 T06 F013A	1135-1-G	VG 95343 T07 E003A	1155-4-GP
VG 95343 T06 B004A	155-42-G	VG 95343 T06 F014A	1136-1-G	VG 95343 T07 E004A	1156-4-GP
VG 95343 T06 B005A	156-42-G	VG 95343 T06 J002A	1112-1-G	VG 95343 T07 E005A	1157-4-GP
VG 95343 T06 B006A	157-42-G	VG 95343 T06 J004A	1114-1-G	VG 95343 T07 E006A	1158-4-GP
VG 95343 T06 B007A	158-42-G	VG 95343 T06 J006A	1116-1-G	VG 95343 T07 E007A	1159-4-GP
VG 95343 T06 B008A	159-42-G	VG 95343 T06 J007A	1117-1-G	VG 95343 T07 E008A	1160-4-GP
VG 95343 T06 B009A	160-42-G	VG 95343 T06 J008A	1118-1-G	VG 95343 T07 F001A	1121-4-GP
VG 95343 T06 C001A	157-43-G	VG 95343 T07 A001A	152-41-GP	VG 95343 T07 F002A	1122-4-GP
VG 95343 T06 C002A	158-43-G	VG 95343 T07 A002A	153-41-GP	VG 95343 T08 A002A	1209-1-G
VG 95343 T06 C003A	159-43-G	VG 95343 T07 A003A	154-41-GP	VG 95343 T08 A004A	1210-1-G
VG 95343 T06 C004A	160-43-G	VG 95343 T07 A004A	155-41-GP	VG 95343 T08 A007A	1201-1-G
VG 95343 T06 D001A	129-1-G	VG 95343 T07 A005A	156-41-GP	VG 95343 T08 A009A	1206-1-G
VG 95343 T06 D002A	130-1-G	VG 95343 T07 A006A	157-41-GP	VG 95343 T08 A010A	1202-1-G
VG 95343 T06 D003A	131-1-G	VG 95343 T07 A007A	158-41-GP	VG 95343 T08 A011A	1207-1-G
VG 95343 T06 D004A	132-1-G	VG 95343 T07 A008A	159-41-GP	VG 95343 T08 A016A	1204-1-G
VG 95343 T06 D005A	133-1-G	VG 95343 T07 A009A	160-41-GP	VG 95343 T08 A017A	1216-1-G
VG 95343 T06 D006A	134-1-G	VG 95343 T07 B001A	152-42-GP	VG 95343 T08 B001A	1301-1-G
VG 95343 T06 D007A	135-1-G	VG 95343 T07 B002A	153-42-GP	VG 95343 T08 B002A	1303-1-G
VG 95343 T06 D008A	136-1-G	VG 95343 T07 B003A	154-42-GP	VG 95343 T08 B003A	1311-1-G
VG 95343 T06 D009A	138-1-G	VG 95343 T07 B004A	155-42-GP	VG 95343 T08 B004A	1302-1-G
VG 95343 T06 D010A	187-1-G	VG 95343 T07 B005A	156-42-GP	VG 95343 T08 B010A	1306-1-G
VG 95343 T06 D011A	176-1-G	VG 95343 T07 B006A	157-42-GP	VG 95343 T08 B011A	1307-1-G
VG 95343 T06 D012A	177-1-G	VG 95343 T07 B007A	158-42-GP	VG 95343 T08 C001A	206-1-G
VG 95343 T06 D013A	178-1-G	VG 95343 T07 B008A	159-42-GP	VG 95343 T08 C002A	203-1-G
VG 95343 T06 D 014A	179-1-G	VG 95343 T07 B009A	160-42-GP	VG 95343 T08 C003A	204-1-G
VG 95343 T06 E001A	1152-4-G	VG 95343 T07 C001A	157-43-GP	VG 95343 T08 C005A	212-1-G
VG 95343 T06 E002A	1154-4-G	VG 95343 T07 C002A	158-43-GP	VG 95343 T08 D001A	306-1-G
VG 95343 T06 E003A	1155-4-G	VG 95343 T07 C003A	159-43-GP	VG 95343 T08 D002A	304-1-G
VG 95343 T06 E004A	1156-4-G	VG 95343 T07 C004A	160-43-GP	VG 95343 T08 D003A	310-1-G
VG 95343 T06 E005A	1157-4-G	VG 95343 T07 F003A	1123-4-GP	VG 95343 T08 D004A	311-1-G
VG 95343 T06 E006A	1158-4-G	VG 95343 T07 F004A	1124-4-GP	VG 95343 T08 E002A	411-1-G
VG 95343 T06 E007A	1159-4-G	VG 95343 T07 F005A	1125-4-GP	VG 95343 T08 E004A	403-1-G
VG 95343 T06 E008A	1160-4-G	VG 95343 T07 F006A	1126-4-GP	VG 95343 T08 E005A	413-1-G
		VG 95343 T07 F007A	1127-4-GP	VG 95343 T09 A001A	1203-1-GP
		VG 95343 T07 F008A	1128-4-GP	VG 95343 T09 A002A	1209-1-GP
		VG 95343 T07 F009A	1129-4-GP	VG 95343 T09 B001A	1301-1-GP
		VG 95343 T07 F010A	1141-4-GP	VG 95343 T09 B002A	1303-1-GP
		VG 95343 T08 A001A	1203-1-G	VG 95343 T09 B003A	1311-1-GP
				VG 95343 T09 C001A	206-1-GP
				VG 95343 T09 C002A	203-1-GP
				VG 95343 T09 C003A	204-1-GP
				VG 95343 T15 A0001	V9500

Important Notice

IMPORTANT NOTICE

All statements, technical information and recommendations related to the Seller's products are based on information believed to be reliable, but the accuracy or completeness thereof is not guaranteed. Before utilising the product, the user should determine the suitability of the product for its intended use. The user assumes all risks and liability whatsoever in connection with such use.

Any statement or recommendations of the Seller which are not contained in the Seller's current publications shall have no force or effect unless contained in an agreement signed by an authorised officer of the Seller. The statements contained herein are made in lieu of all warranties, express or implied, including but not limited to the implied warranties of merchantability and fitness for a particular purpose which warranties are hereby expressly disclaimed.

SELLER SHALL NOT BE LIABLE TO THE USER OR ANY OTHER PERSON UNDER ANY LEGAL THEORY, INCLUDING BUT NOT LIMITED TO NEGLIGENCE OR STRICT LIABILITY, FOR ANY INJURY OR FOR ANY DIRECT OR CONSEQUENTIAL DAMAGES SUSTAINED OR INCURRED BY REASON OF THE USE OF ANY OF THE SELLERS PRODUCTS THAT WERE DEFECTIVE.



HellermannTyton

HEADQUARTERS

William Prance Road

Plymouth International Medical and Technology Park
Plymouth,
Devon
PL6 5WR
England

Telephone: +44 (0)1752 761211
Fax: +44 (0)1752 761210
www.hellermanntyton.co.uk

U.S. OFFICE

2024 Liverpool Drive
Plano
Texas
75025
U.S.A.

Tel: 001 469 361 6678
Fax: 001 469 361 6671
www.hellermanntyton.co.uk

E-mail - cholland@htamericas.com

HellermannTyton Cage Code: K0720